

LT 40/A CLASSIC DUST SEPARATOR

LT40/A dust separator - Code CI540

The **LT40/A CLASSIC dust separator** is designed for **modular applications**, such as integration with Aertecnica motor modules.

Suitable for systems with an **operational air flow rate of up to 300 m³/h *** and for integration into existing vacuum systems, it allows for the **separate collection of materials that require differentiated management**.

The LT40/A Separator is suitable for vacuum systems **in the Tertiary and Residential sectors**.

It is ideal for working with 1 or 2 operators simultaneously using a Ø32 mm flexible hose.

The **23.000 cm polyester filter cartridge** makes it suitable for numerous professional applications, ensuring efficiency and reliability over time.

The **dust container** has a **40-liter capacity** and is **equipped with a conveying cone** that facilitates dust accumulation at the bottom.

Wall mounting and compact dimensions allow for extremely flexible installation, even in limited technical spaces.

*** For central vacuum units with operating airflow rates exceeding 300 m³/h, multiple separators connected in parallel are required.**



CI540



Complementary accessories



CI818 - LT40/A (CI540) Bags for separator
(10 pieces pack)

Spare parts
Contains protection kit with mask and gloves



CI880- Filter cartridge for LT40/A (CI540) separator
in polyester lavable - dimensions: 61 cm H x Ø27 cm

Spare parts
Contains protection kit with mask and gloves

CLASSIC dust separator		
Model		LT40/A
Commercial code		CI540
Number of simultaneous operators	n°	2
Max air flow rate	m ³ /h	300
Filter cartridge surface	cm ²	23.000
Filter cartridge material	-	polyester lavable
Dust container capacity	litres	40
Separator body diameter	cm	36
Separator body height	cm	120
Dust inlet diameter	Ø	63
Air exhaust diameter	Ø	63
Weight	kg	22

LT40/A SEPARATOR WITH MODULAR CENTRAL UNIT CONNECTIONS (example)

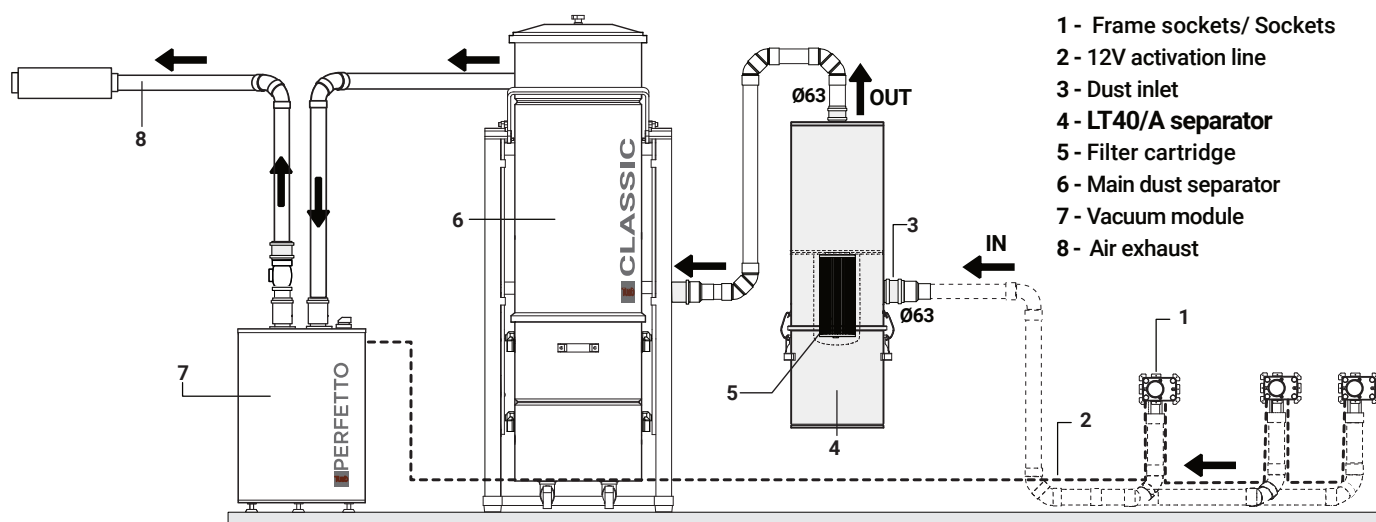

OVERALL DIMENSIONS (in cm)

