

TUBO®

Smart Vacuum Net

USER, INSTALLATION AND MAINTENANCE MANUAL



KOMPATTA KT central power units

MODELS: KT10 - KT10A
KT20M - KT20MA
KT20 - KT20A - KT20A AUX
KT30 - KT30A - KT30A AUX

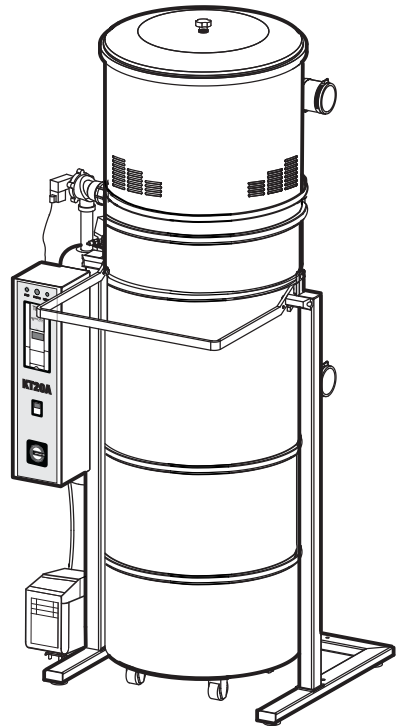
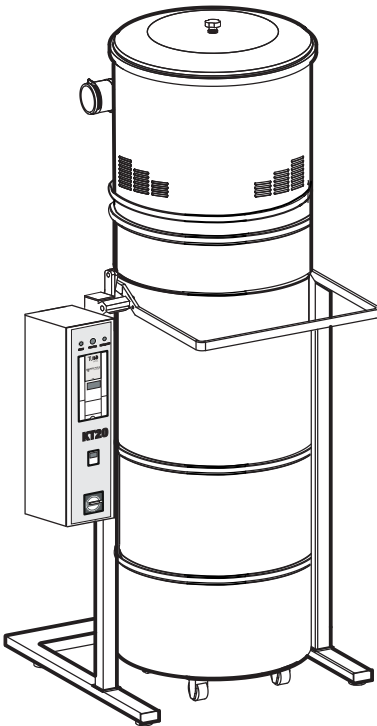

EN

Version translated from the original

 **AERTECNICA®**
think clean

INDEX

GENERAL INFORMATION

- 3 EU Declaration of Conformity
- 4 General warnings
- 4 Warranty
- 5 Safety
- 5 Manufacturer
- 5 Technical assistance
- 6 Identification plate
- 7 Technical data
- 9 Description of parts
- 10 Intended use
- 10 Incorrect use
- 10 Operator

ORDINARY MAINTENANCE

- 38 Emptying the container
- 40 Filter cartridge replacement
- 41 Filter cartridge regeneration
- 42 Unit disposal
- 43 Troubleshooting

INSTALLATION

- 11 Transport
- 11 Installation local
- 11 Placing
- 12 Unit installation measurements
- 13 Inlet line connection dust
- 14 Exhaust line connection
- 14 Electric connection
- 15 Kompatta KT alimantation
- 17 Connection to vacuum sockets line
- 17 Kompatta KT starting and shutting down
- 18 Air cleaning AUX - Auxiliary compressed air connection
- 19 Kompatta KT control panel functions
- 20 Air cleaning and Air cleaning AUX self-cleaning system
- 21 Air cleaning system command clock
- 25 Kompatta KT testing
- 26 Fault reports and solutions

EC CONFORMITY DECLARATION OF A MACHINE



The manufacturer **Aertecnica S.P.A** declares under its own responsibility that the product:

SERIES: KOMPATTA KT CENTRAL POWER UNIT

MODELS: KT10 - KT10A - KT20M - KT20MA - KT20 - KT20A - KT30 - KT30A

COMPLIES WITH

to the essential health and safety requirements established by the following Directives:
The Directive 2006/42/EC (Machinery directive) and subsequent amendments and additions.

The Directive 2014/30/UE (EMC directive) and subsequent amendments and additions.

The Directive RoHS III 2011/65/UE (Dangerous substances and limits) and subsequent amendments and additions.

APPLIED HARMONIZED STANDARDS:

EN ISO 12100:2010

IEC 60335-1:2012 + A11:2014, A13:2017, A1:2019, A14:2019, A2:2019, A15:2021

IEC 60335-2-69:2012

EN 62233:2008

EN IEC 61000-6-2:2019

EN IEC 61000-6-4:2019

EN IEC 61000-3-2:2019 + A1:2021

EN 61000-3-3:2013 + A1:2019 + A2:2021

The declarant

Daniele Golinucci

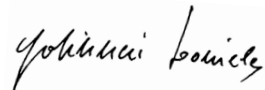

CESENA, li 14/10/2025

GENERAL INFORMATION

GENERAL WARNINGS

Carefully read the manual

The installation, user and maintenance manual is an integral and essential part of the central power unit and must be read carefully as it contains important information concerning operator safety, foreseen operation and the correct maintenance of the central power unit.

LIABILITY

The central power unit must only be implemented for the use for which it was explicitly designed (see paragraph INTENDED USE).

Any other use is considered incorrect and therefore dangerous (see paragraph INCORRECT USE).

The central power unit should not be used by people with reduced physical, sensorial or mental capacities, by children or by people without product experience or knowledge, unless they are supervised or have been instructed in the use of the central power unit by a person responsible for their safety.

The manufacturer shall not accept any contractual and extra contractual liability due to damage caused by errors in using and installing the central power unit or due to failure to observe the instructions provided by the manufacturer.

ATTENTION

AERTECNICA reserves the right to modify the product and the related technical documentation without incurring any obligation towards third parties.

No part of this manual may be reproduced, copied or distributed in any manner without written authorisation from Aertecnica.

WARRANTY

Warranty conditions for the European Union

Aertecnica ensures the correct operation of the purchased central power unit for a period of 24 months from the documented date of purchase.

If there is no documentation that proves the purchase date (invoice or tax receipt), the 24-month period will refer to the date it was sold by AERTECNICA. Any additional warranty conditions will be exclusively charged to those who offer them.

For any dispute, the Court of Forlì-Cesena (ITALY) shall have exclusive jurisdiction and Italian law will apply.

Warranty conditions outside the European Union

For countries outside of the European Union the guarantee shall be borne by the importing company and the warranty conditions are those provided by the law of the country where the product is imported to.

SAFETY

The operator must accurately comply with the operating instructions shown by the pictograms in order to guarantee the safety of persons and correct operation of the central power unit.



DANGER: this indicates that attention must be paid in order to prevent events that could cause serious accidents that may harm people or their health.



ELECTRICAL DANGER: make sure that the central power unit is connected with the relative cable to a standard compliant earthing system.

The electricity mains and relevant socket must be appropriate to the rated power of the central power unit.



ELECTRICAL DANGER: make sure that the central power unit is connected with the relative cable to a standard compliant earthing system.



The electricity mains and relevant socket must be appropriate to the rated power of the central power unit.



RISK OF CRUSHING: during handling and installation phases of the central power unit, we recommend the use of suitable means for lifting and carrying out the installation as described, in order to avoid the unit accidentally falling. Do not insert your upper limbs inside the unhooking/hooks mechanism of the dust container.



INHALATION OF HARMFUL ELEMENTS AND DUST:

protect respiratory organs by using protective masks when emptying the dust containers and when replacing the filter cartridge so the collected dust is not inhaled.



SENSIVITY TO DUST: this means that hand protection must be used to prevent any harm to operators who are sensitive to the collected dust.

CERTIFICATIONS

AerTECNICA S.p.A is a company certified with:



Quality system UNI EN ISO 9001

IDENTIFICATION

This user and maintenance manual refers to the following models of the Central power unit:

SERIES: KOMPATTA KT

**MODELS: KT10 - KT10A - KT20M - KT20MA
KT20 - KT20A - KT20A AUX
KT30 - KT30A - KT30A AUX**

MANUFACTURER

AERTECNICA S.p.A.

Via Cerchia di Sant'Egidio, 760
47521 Cesena (FC) ITALY

Tel. +39 0547/637311

info@aerTECNICA.com

www.aerTECNICA.com

TECHNICAL SERVICE

The Technical Service Centre can be contacted for all technical problems and if spare parts are needed. For all communications concerning the central power unit, the user should always provide the following data:

model of the central power unit

serial number

year of manufacture

purchase date and detailed information about the issues found.

IDENTIFICATION PLATE

The identification plate is located on the body of the central power unit as shown in the figure.

Kompatta KT with Air cleaning and Air cleaning AUX self-cleaning system

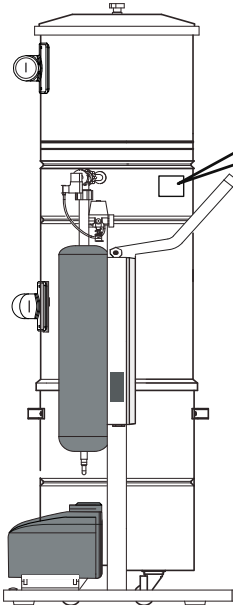

TUBO	<small>by</small> AERTECNICA Think clean	CE	Aertecnica S.p.A. via Cerchia di Sant'Egidio, 760 47521 Cesena, FC - Italy Tel 0039 0547 637311	
			Model	Serial N°
Net weight		Year		
	Self-cleaning		Motor	
Absorbed current	<input type="text"/> A		<input type="text"/> A	
Voltage	<input type="text"/> V		<input type="text"/> V	
Power	<input type="text"/> kW		<input type="text"/> W	
Frequency	<input type="text"/> Hz		<input type="text"/> Hz	
Dust container capacity	<input type="text"/> lt			
Tank capacity	<input type="text"/> lt			
Max working pressure	<input type="text"/> Bar			

Kompatta KT without self-cleaning system

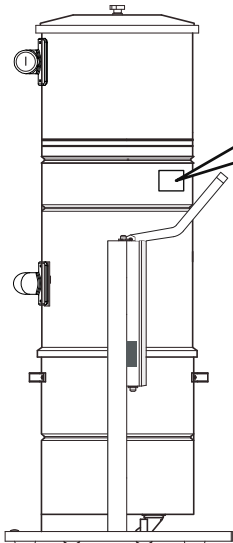

TUBO	<small>by</small> AERTECNICA Think clean	CE	Aertecnica S.p.A. via Cerchia di Sant'Egidio, 760 47521 Cesena, FC - Italy Tel 0039 0547 637311	
			Model	Serial N°
Voltage	<input type="text"/> V	Year	<input type="text"/>	
Absorbed current	<input type="text"/> A	Net weight	<input type="text"/> kg	
Frequency	<input type="text"/> Hz			
Power	<input type="text"/> W			

TECHNICAL DATA

Kompatta KT Air Cleaning and Air Cleaning AUX central power units							
MODELS		KT20A	KT20A AUX	KT20	KT30A	KT30A AUX	KT30
COMMERCIAL CODE		CIKT20A	CIKT20A.1	CIKT20	CIKT30A	CIKT30A.1	CIKT30
Simultaneous operators*	n°	2	2	2	3	3	3
Air Cleaning system	-	Yes	Yes - AUX	No	Yes	Yes - AUX	No
Air compressor	-	Yes	No	No	Yes	No	No
Auxiliary compressed air line connection	-	No	Yes - AUX	No	No	Yes - AUX	No
Self-cleaning system operating pressure	Bar	> 4	> 4	> 4	> 4	> 4	> 4
Self-cleaning tank capacity	litres	12	12	-	12	12	-
Inverter	-	Yes	Yes	Yes	Yes	Yes	Yes
Alimentation	Volt	380/400	380/400	380/400	380/400	380/400	380/400
Motor power	W	3.000	3.000	3.000	4.800	4.800	4.800
Maximum absorption	A	7	7	7	9	9	9
Frequency	Hz	50-60	50-60	50-60	50-60	50-60	50-60
Motor revolutions	rpm	3.900	3.900	3.900	3.600	3.600	3.600
Maximum vacuum	mBar	370	370	370	490	490	490
Air flow	m³/h	475	475	475	670	670	670
Soft Start starting	-	Yes	Yes	Yes	Yes	Yes	Yes
Power sockets	Volt	12	12	12	12	12	12
Filter cartridge surface	cm²	50.000	50.000	50.000	50.000	50.000	50.000
Filter cartridge material	-	polyester	polyester	polyester	polyester	polyester	polyester
Dust Container capacity	litres	150	150	150	150	150	150
Central unit diameter	cm	56	56	56	56	56	56
Dust inlet diameter	mm	80	80	80	80	80	80
Air expulsion diameter	mm	80	80	80	80	80	80
Weight	kg	152	143	134	152	143	134
Noyse	dB	<70	<70	<70	<70	<70	<70
Recommended surface (up to)	m²	2.000	2.000	2.000	3.000	3.000	3.000

* only for Ø50 traditional vacuum system

TECHNICAL DATA

Kompatta KT central power units					
MODELS		KT10	KT10A	KT20M	KT20MA
COMMERCIAL CODE		CIKT10	CIKT10A	CIKT20M	CIKT20MA
Simultaneous operators*	n°	1	1	2	2
Air Cleaning system	-	No	Yes	No	Yes
Self-cleaning system operating pressure	Bar	-	> 4	-	> 4
Self-cleaning tank capacity	litres	-	12	-	12
Inverter		No	No	Yes	Yes
Alimentation	Volt	380/400	380/400	220/240	220/240
Motor power	W	2.200	2.200	2.600	2.600
Maximum absorption	A	6,5	6,5	19	19
Frequency	Hz	50-60	50-60	50-60	50-60
Motor revolutions	rpm	3.000	3.000	3.600	3.600
Maximum vacuum	mBar	370	370	370	370
Air flow	m³/h	348	348	431	431
Soft Start starting	-	No	No	Yes	Yes
Power sockets	Volt	12	12	12	12
Power sockets	cm²	50.000	50.000	50.000	50.000
Filter cartridge surface	-	polyester	polyester	polyester	polyester
Filter cartridge material	litres	150	150	150	150
Dust Container capacity	cm	56	56	56	56
Central unit diameter	mm	80	80	80	80
Dust inlet diameter	mm	80	80	80	80
Air expulsion diameter	kg	134	143	134	152
Noyse	dB	<70	<70	<70	<70
Recommended surface (up to)	m²	1.000	1.000	2.000	2.000
* only for Ø50 traditional vacuum system					

DESCRIPTION OF PARTS

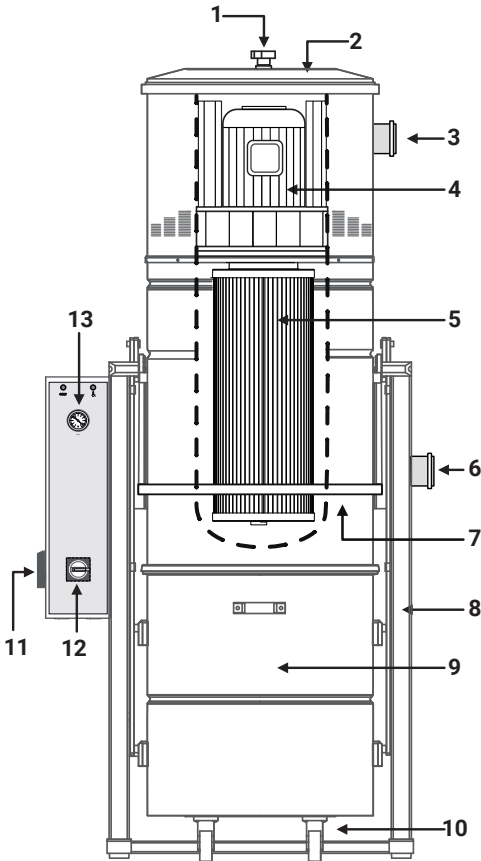

on all models of dust Kompatta KT

- 1 - Kompatta KT cover fixing knob
- 2 - Cover
- 3 - Air expulsion outlet
- 4 - Side channel turbine
- 5 - Filter cartridge
- 6 - Dust inlet opening
- 7 - Dust container opening/closing handle
- 8 - Support frame
- 9 - Dust container
- 10 - Swivel wheels
- 11 - Electric panel power supply
- 12 - ON/OFF switch
- 13 - Analogic display (*only for KT10 and KT10A models*)

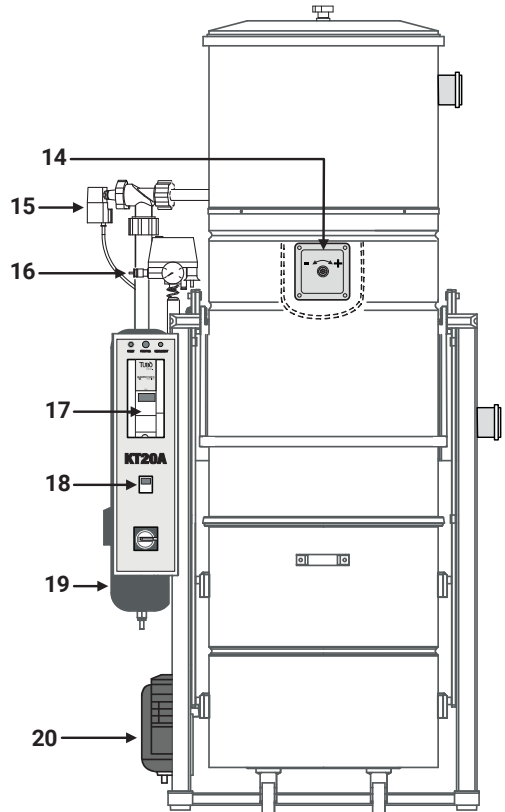

only on Kompatta KT Air Cleaning models

- 14 - Compensation valve
- 15 - Solenoid valve
- 16 - Safety valve
- 17 - Electric panel with Inverter
- 18 - Air Cleaning programming clock
- 19 - Self-cleaning tank
- 20 - Air compressor for self-cleaning system (*absent on AUX models*)

INTENDED USE

The **Kompatta KT** has been designed **to aspire only class L dust**, including common household dust, earth and lime dust considered to be low toxicity dust.

The dust collection bag must be replaced with a new one every time it fills.

The filter cartridge can be regenerated periodically, and should be changed at least every 2-3 years or immediately in the event of breakage.



Wear personal protective garments before emptying the dust container



or replacing/cleaning the filter cartridge.

INCORRECT USE

In order to guarantee proper operation of the central power unit and to prevent the relative warranty coverage from lapsing, follow the instructions provided below:

- Do not vacuum lighted cigarettes, hot embers or burning material: these materials may cause a fire to start that would damage the hoses and the central power unit.
- Do not vacuum cloths, rags, fabrics or textile material: these materials could obstruct the hoses or damage the central power unit .
- Do not vacuum liquids, materials saturated with liquids or very moist materials: these materials could cause the electric system to short circuit, prevent the proper passage of the dust or damage the sockets and the central power unit.
- Do not allow children to play with the vacuum sockets, opening and closing them continuously or inserting toys or solid items of unsuitable dimensions.
- Do not use the system with the central power unit turned on without the filter cartridge inserted.
- Do not block the air exhaust line.
- Do not block the air sockets for electric motor cooling.
- Do not use the cleaning accessories to vacuum parts of the body.
- Do not leave the central power unit powered when it is not used for prolonged periods of time.

USER

The user must be in good physical and psychological condition.

The user must always be alert during use of the system in order not to trip on the hose or cleaning accessories connected to the system, and must adopt the same safety measures for the persons present in the room with him.

The user must be over the age of 14 years.

INSTALLATION

TRANSPORT

Check the overall mass of the central power unit shown on the identification plate and use the described means for proper handling.

We recommend that you do not remove the packaging until installation so as to prevent any knocks and damage.



Use personal protective equipment during transportation and installation of the unit.

RISK OF CRUSHING



Use a forklift truck during the transport and movement of the central power unit. Proceed at reduced speed, keeping the load at a low level to avoid risks of overturning.



ATTENTION



Packaging parts of the central power unit are inert solid waste that must be disposed of according to current applicable regulations.

MATERIALS	DISPOSAL
ecological cardboard packaging	paper
fir wood ecological pallets	wood
metal carpentry	iron

INSTALLATION LOCATION

The central power unit must be installed in service areas (for example technical compartment, engine room) which are well ventilated and protected from significant temperature changes.

The power supply line of the correct voltage indicated on the unit identification plate, and also the vacuum socket consent line for the activation of the vacuum system, must be set up close to the central power unit. The installation room must be sufficiently large to allow maintenance work.

The temperature of the installation room must be $0^{\circ} \leq$ room temperature $\leq 35^{\circ}$

The installation room must be sufficiently illuminated (minimum 200 lux) to allow maintenance work.

The installation room must have an air exchange rate per hour ≥ 0.5 v/room (volume/room).

The central power unit must not be placed in an environment classified as ATEX.

POSITIONING

Ensure that the levelling of the floor on which the base of the unit rests is optimal. The floor must have adequate structural strength to support the weight of the unit as shown on the identification plate.

Leave the indicated free space (in cm) around the unit, to allow cleaning and maintenance by the operator.

plan view

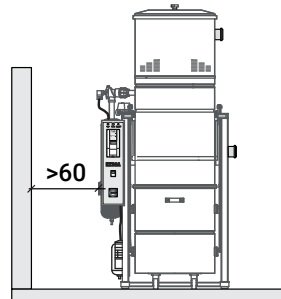
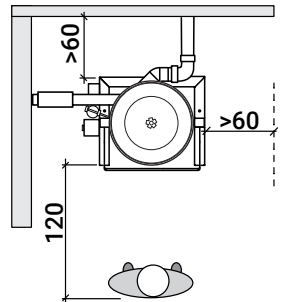

front view

UNIT INSTALLATION MEASUREMENTS (in mm.)

	KT10	KT10A	KT20	KT20A	KT20A AUX	KT30	KT30A	KT30A AUX	KT20M	KT20MA
A	199	199	199	199	199	199	199	199	199	199
B	172	172	172	172	172	172	172	172	172	172
C	84	84	84	84	84	84	84	84	84	84
D	93	93	93	93	93	93	93	93	93	93

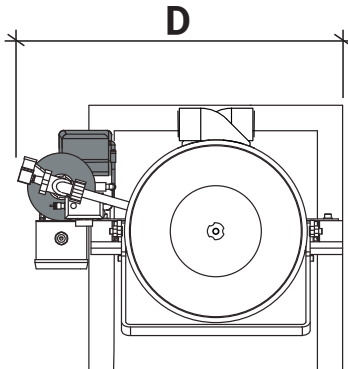
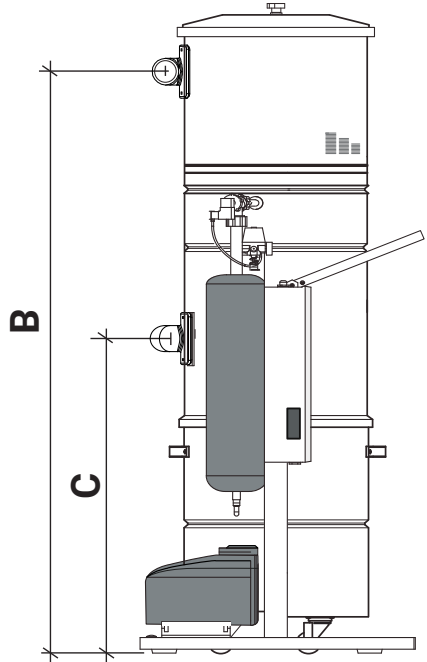
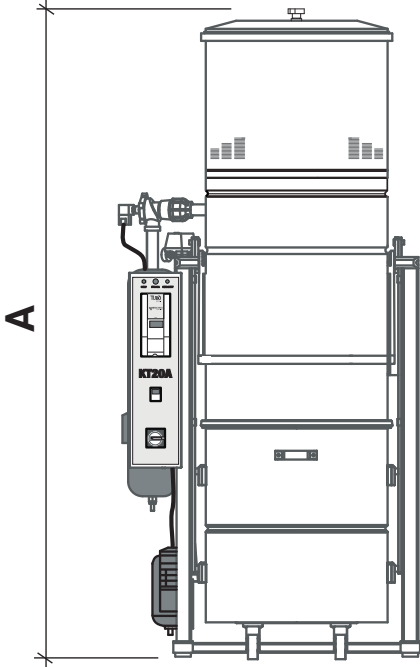

DUST INLET LINE CONNECTION

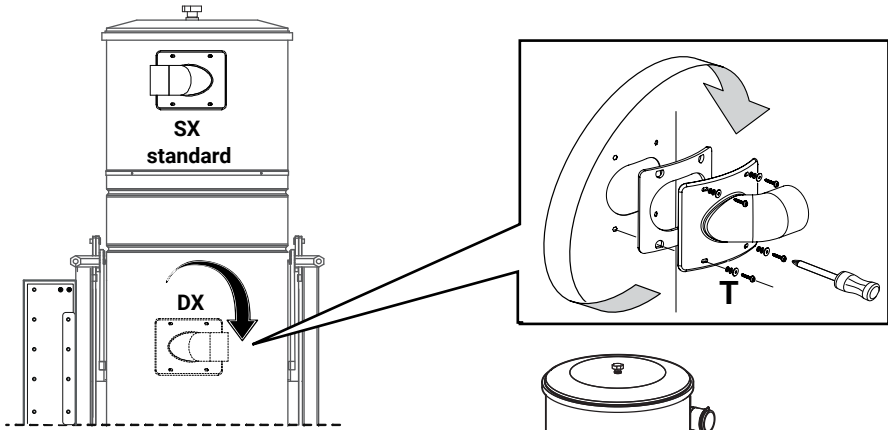

The connection of the central power unit with the dust line is facilitated by the possibility of orienting the inlet opening in two opposite directions, by unscrewing the screws and washers (T) and after rotating the opening putting them back the same way, as indicated on the side.

CONNECTION WITH SLEEVE AND CLAMPS

- A - dust inlet opening
- B - clamps
- C - sleeve
- D - dust input pipe line Ø80

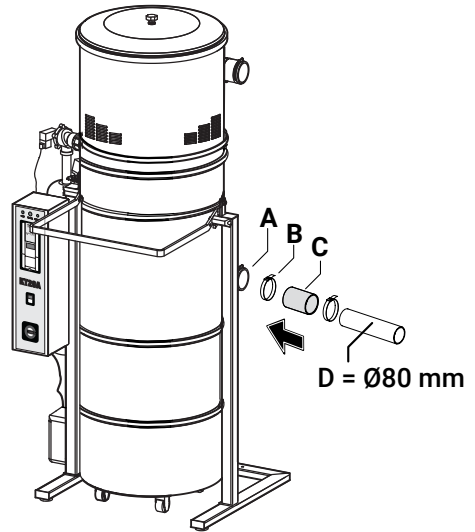

DUST COLLECTOR

The power unit (especially the one for two/three operators) can be connected with more than one dust input line. In this case we recommend that you install a dust collector (N).

EXAMPLE OF DUST COLLECTOR

The collector (N) receives the different dust lines coming from the power unit. At the base of each dust line, we recommend that you install a special ball valve (V) by means of which you can exclude the line from the whole vacuum system of the building.

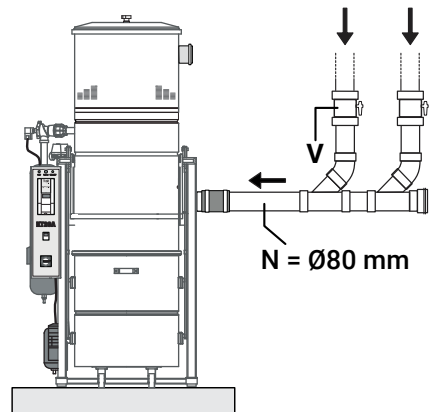

AIR EXHAUST LINE CONNECTION

Install air exhaust line pipe that is no longer than 5 metres.

If the exhaust line is longer, use a larger diameter and mount the silencer of the same diameter.

CONNECTION

- E - air exhaust pipe connector + clamps
- F - air exhaust line pipe
- G - silencer (not supplied)
- H - exhaust grill

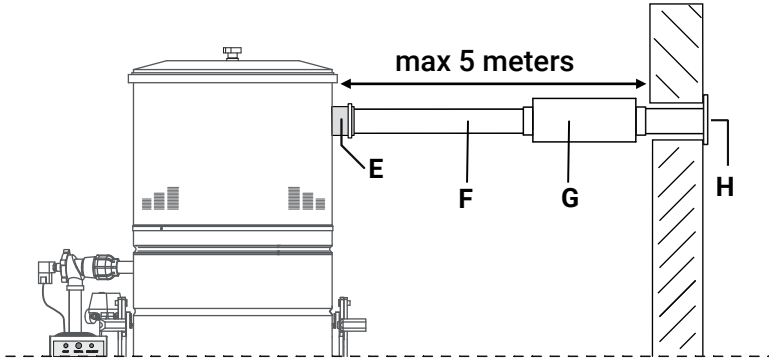

KOMPATTE KT ELECTRICAL CONNECTION

 The electrical system of the central power unit must be made by qualified professionals and in accordance with applicable regulations. The manufacturer assumes no responsibility for malfunction or damage to persons and/or property resulting from the incorrect connection to the electrical system.

 **POWER LINE**
Make sure that the electric line is dimensioned to support the central power unit electrical power and check that the mains network corresponds to the voltage specified on the identification plate.

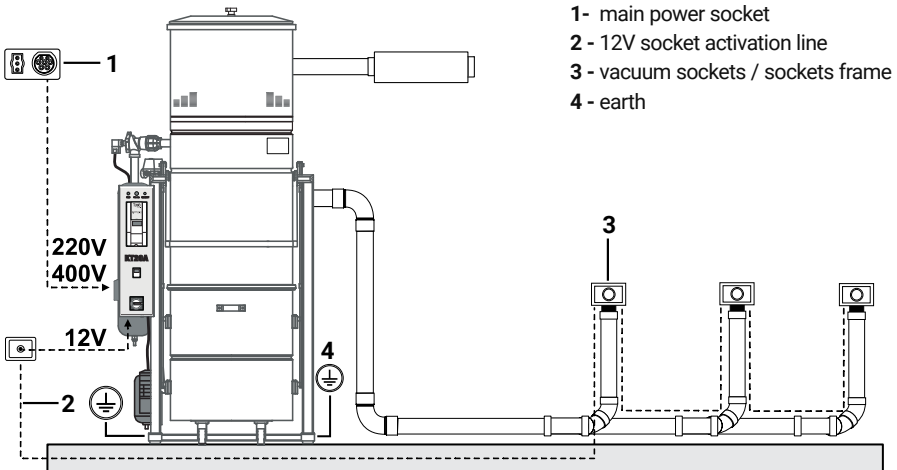

- 1- main power socket
- 2 - 12V socket activation line
- 3 - vacuum sockets / sockets frame
- 4 - earth

KT20A - KT20A AUX - KT30A - KT30A AUX POWER SUPPLY



DIFFERENTIAL

You must connect the power unit to a class B differential for Inverter, not less than 100 mA

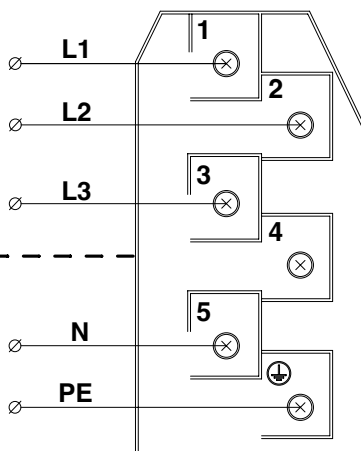
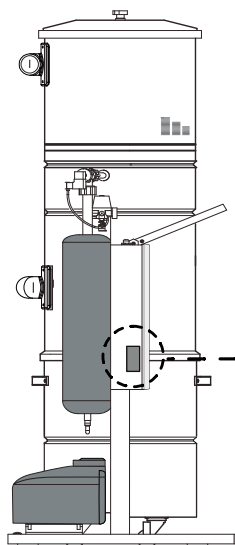

380/400V POWER SUPPLY
TERMINAL STRIP
CONNECTION

KT20 - KT30 POWER SUPPLY



DIFFERENTIAL

You must connect the power unit to a class B differential for Inverter, not less than 100 mA

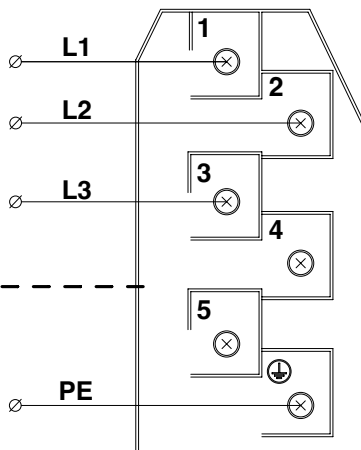
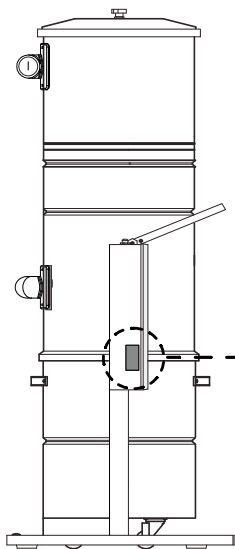

380/400V POWER SUPPLY
TERMINAL STRIP
CONNECTION

KT10 - KT10A POWER SUPPLY



CIRCUIT BREAKER

It's necessary installing a circuit breaker for engine starting.

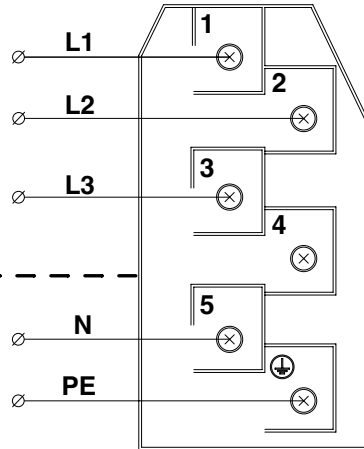
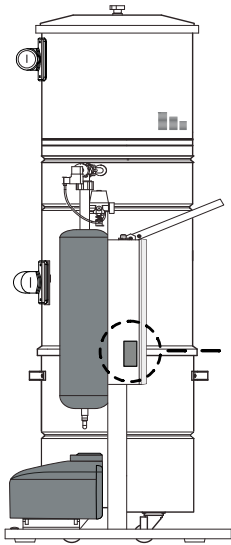

380/400V POWER SUPPLY
TERMINAL STRIP
CONNECTION

KT20M - KT20MA POWER SUPPLY



DIFFERENTIAL

You must connect the power unit to a class B differential for Inverter, not less than 100 mA

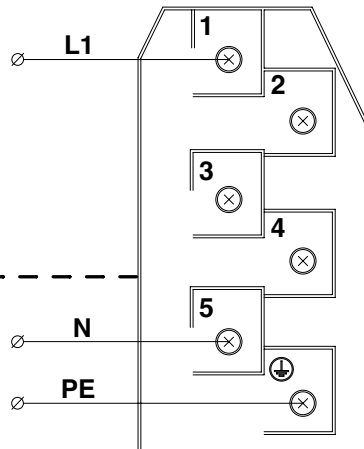
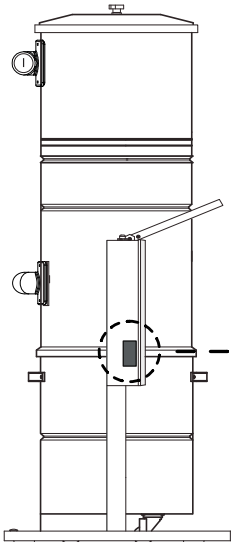

220/240V POWER SUPPLY
TERMINAL STRIP
CONNECTION

CONNECTION TO VACUUM SOCKETS LINE (LP)

The socket line inputs are located under the base plane of the electrical panel.

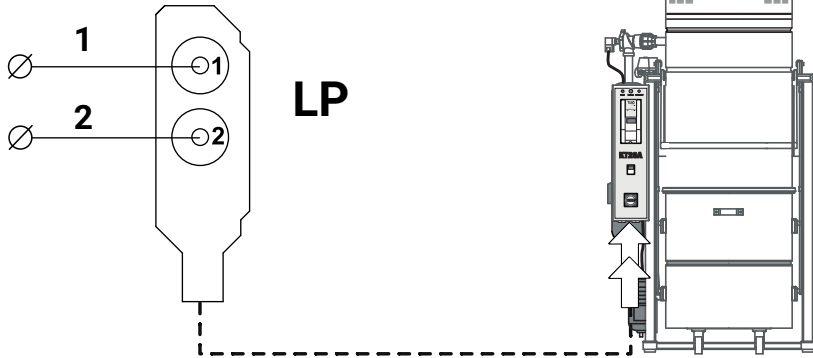

KOMPATTA KT STARTING / SHUTTING DOWN

AVVIAMENTO CENTRALE KOMPATTA KT

The central vacuum unit starts when it receives the initial consent from the power line (LP) connected to the suction sockets of the vacuum cleaner system, and remains in operation as long as the consent is active.

SPEGNIMENTO CENTRALE KOMPATTA KT

The vacuum unit switches off when consent from the power line (LP) is withdrawn.

COMPRESSOR: KT10A - KT20A - KT20AM - KT30A models

The electrical connection of the compressor to the electrical panel is carried out directly by the Manufacturer

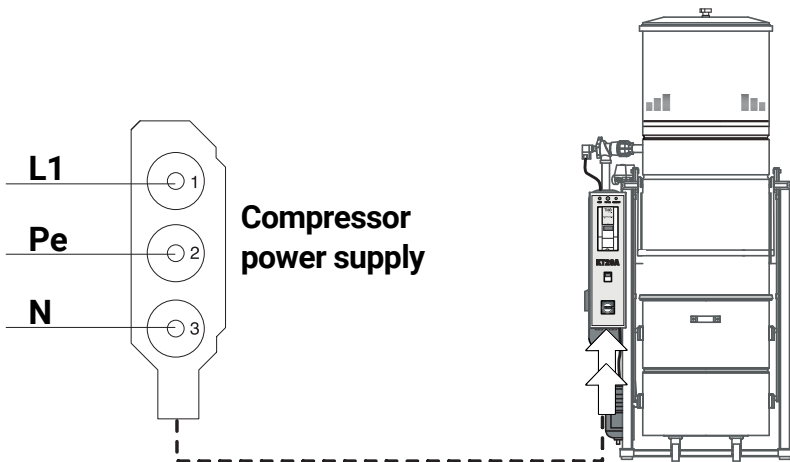

AIR CLEANING AUX KOMPATTA KT - COMPRESSED AIR CONNECTION

only for KT20A AUX and KT30A AUX models

The AIR CLEANING AUX Kompatta KT is designed by Aertecnica to be connected to the compressed air line or to a compressor already present in the room where it is used.

ATTENTION

The system includes a pressure regulator with a 3/8 female quick coupling and a male quick tap. **For correct operation, an operating pressure greater than 4 bar is required.**

CONNECTION

Connect the existing compressed air line (L) to the fitting (R) of the separator, as shown in the figure.

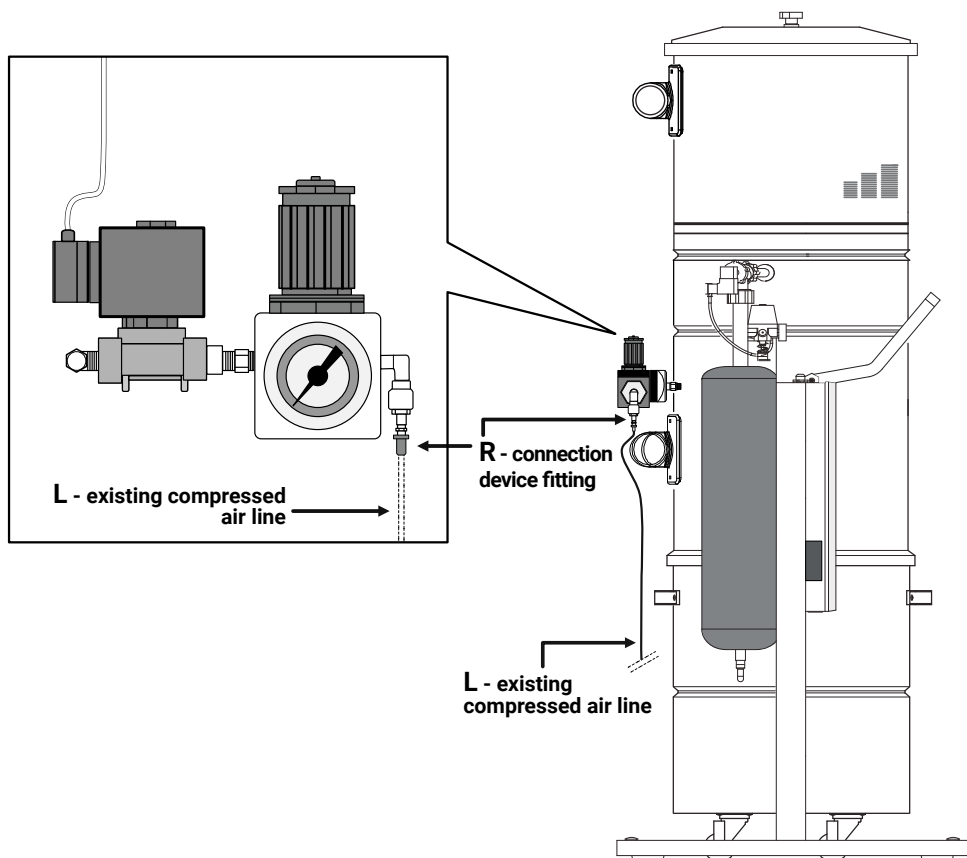

CONTROL PANELS - FUNCTIONALITY

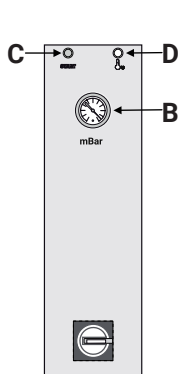

KT10

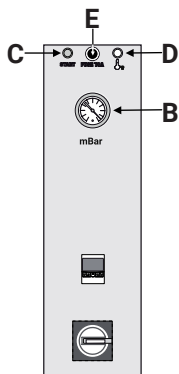



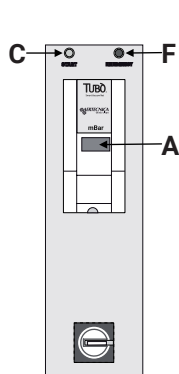

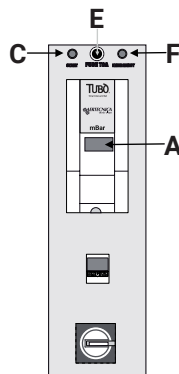

KT10A



KT20 - KT30
KT20M



KT20A - KT20A AUX
KT30A - KT30A AUX
KT20M

A		DIGITAL DISPLAY: KT20 - KT30 - KT20M - KT20A - KT20A AUX KT30A - KT30A AUX - KT20M Indicates the working frequency value of the power plant (Hz)
B		ANALOGIC DISPLAY: KT10 / KT10A Indicates the working pressure parameter (mBar)
C		GREEN LIGHT - START Indicates that motor is running
D		RED LIGHT - TEMPERATURE The warning light will turn on when the central power unit motor chamber overheats. In such an instance, the central power unit will turn off. The turbine motor must cool down before restarting the central power unit.
E		COMPRESSOR PROTECTIVE FUSE FOR SELF-CLEANING Only for KT10A / KT20MA / KT20A / KT20A AUX / KT30A / KT30A AUX models The compressor protective fuse is present on units featuring Auto-cleaning; it should be replaced in the instance where it is burnt out. The fuse is type 5x20 8A .
F		INVERTER BLOCKAGE SPY - EMERGENCY Indicates a central blockage due to anomalies

RESET - CENTRAL POWER UNIT LOCK

If the central vacuum unit locks out due to a fault, the error code E4.....E94 appears on the display. To reset the lockout, turn off the unit at the main switch and wait until the lights on the electrical panel go out, then power the unit back on.

AIR CLEANING SYSTEM

All the self-cleaning system regulation devices such as the pressure switch and the safety valve are already calibrated by the manufacturer and do not need to be modified.

The air self-cleaning system keeps the filter free of obstructions, thus improving suction efficiency and reducing routine maintenance.

The system generates short bursts of air in the opposite direction to the normal suction flow, shaking and loosening dust accumulated on the filter.

Self-cleaning can be activated automatically by clock, setting daily cycles at regular intervals, or manually using the button.

The frequency of automatic cleaning cycles must be set based on system use and the type of material being vacuumed.

HOW TO SET SELF-CLEANING

Air Cleaning Systems with integrated compressor: KT10A / KT20A / KT30A

We recommend setting the self-cleaning time to 5% of the system's daily usage time (max. 5 minutes).

Example: 1 hour of system use = 3 minutes of self-cleaning.

If the self-cleaning time is longer than 5 minutes, program an additional time slot at least 30 minutes apart.

Example: 3 hours of system use = 4 minute of self-cleaning with 2 programs.

Air Cleaning AUX systems with auxiliary compressed air line connection: KT20A AUX / KT30A AUX.

It is recommended to set the self-cleaning operating time equal to 2% of the daily usage time of the system.

Example: 1 hour of system use = 1 minute of self-cleaning.

For intensive applications, the self-cleaning cycle time and daily program frequency can be increased.

ATTENTION

 The Kompatta KT self-cleaning system is set to an operating pressure value ≤ 4 Bar. The tank falls within segment B regulated by Directive 2014/29/EU, relating to simple pressure vessels manufactured in series.

NOTE

The safety valve (P) intervenes if the maximum pressure threshold is exceeded, discharging the excess pressure.

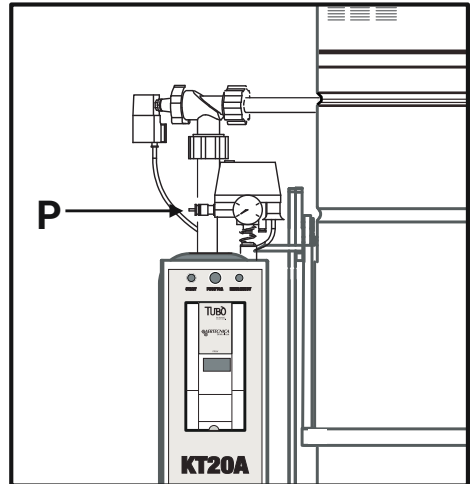

NOTE

It is advisable to use the self-cleaning system when the vacuum cleaner is not in operation.



AIR CLEANING SYSTEM CONTROL CLOCK (Q)

When the Kompatta KT is powered, the display parameters that intervene in the Air Cleaning self-cleaning system are:

1 - Low battery status symbol

2 - Hour /
Date

3 - Manual operation:
"temporary" C1 (flashing)
"permanent" C1 (steady)

4 - C1 relay status symbol **ON** **OFF**
 

5 - Scrolling down in menus /
C1 manual relay operation

6 - Scrolling up in menus

7 - Cancel operation /
Back to menu

8 - OK /

Access the menu /
Activate the display without power

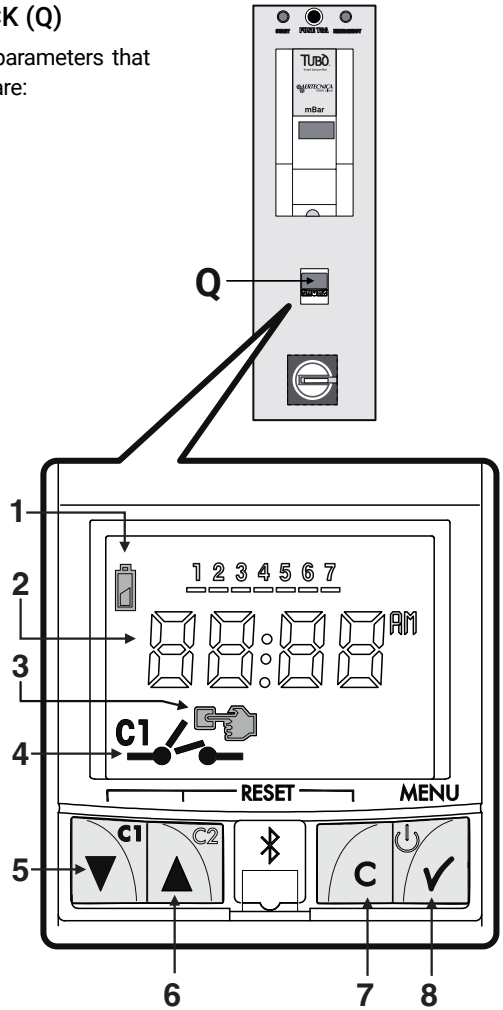

PROGRAMMING

Programming is based on menus and submenus that can be used to set operations or adjust the device.

The **MAIN MENU** can be accessed from the standby screen by pressing

With keys ▼ and ▲ we will move through the different menus and by pressing we will access them

To go back to the previous menu we **press C**.

The details to be programmed appear on screen until you confirm it with the button

MAIN MENU

Below is the main menu structure:

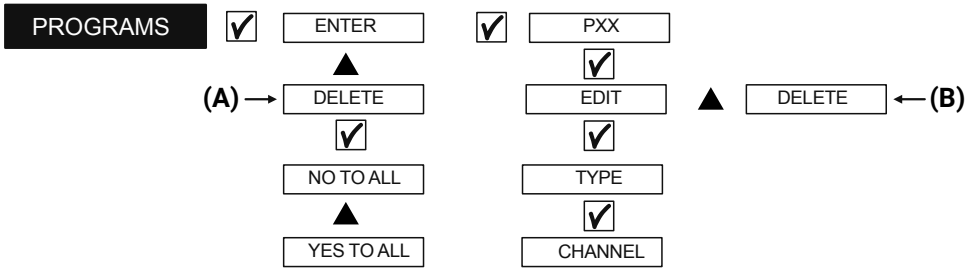

Under the SETTINGS menu you can manage the following parameters:

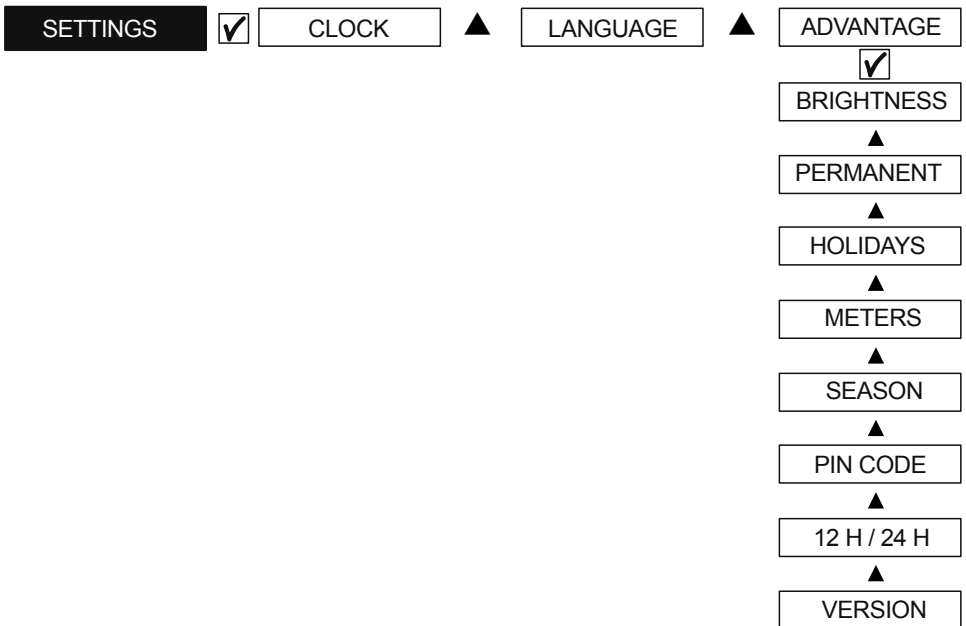

PROGRAMS

In the PROGRAMS MENU are available 40 memory spaces (**P-01 to P-40** programs).

ENTER - We enter by pressing .

When entering this menu, if any programs have already been stored, the first program that was stored appears in the display text line: "**P-01**" and with the taste **▲** key we can go up the different stored programs until we reach the first empty program, in which the display text line will show "**P-XX EMPTY**" alternating with the number of programs available left in the memory of the device.

When entering this menu, if no other programs have been created, the display text line will show: "**P-01 EMPTY**" alternating with "40 LEFT" referring to the memory spaces available.

If we wish to modify or create a program we move to it with the **▼** or **▲** keys, and press we select one of the following options :

- **EDIT** the screen displays alternately: **EDIT** and "**P-01**"..."**P-40**" with time, days and status of the flashing relay; by pressing we move on to choosing the type of operation:
- **TYPE ON**: Switch-on of the connected circuit at a fixed time;
- **TYPE OFF**: Switch-off of the connected circuit at a fixed time;

Next, we enter the operation starting hours and the rest of the necessary times according to the selected operation.

Example:

To set the self-cleaning to turn on at 2.00 pm, I select parameter P01 as shown below:

MENU	<input checked="" type="checkbox"/>	PROGRAMS	<input checked="" type="checkbox"/>	ENTER	<input checked="" type="checkbox"/>	P01	<input checked="" type="checkbox"/>	EDIT	<input checked="" type="checkbox"/>	TYPE	ON	<input checked="" type="checkbox"/>
		Channel	<input checked="" type="checkbox"/>	Hour and min	<input checked="" type="checkbox"/>	Days of the week	<input checked="" type="checkbox"/>					
		C1	<input checked="" type="checkbox"/>	14.00	<input checked="" type="checkbox"/>	MON...SUN	<input checked="" type="checkbox"/>	P01 OK				

We choose to perform the switch-off program at 14.05, I select parameter P02 as shown below:

MENU	<input checked="" type="checkbox"/>	PROGRAMS	<input checked="" type="checkbox"/>	ENTER	<input checked="" type="checkbox"/>	P02	<input checked="" type="checkbox"/>	EDIT	<input checked="" type="checkbox"/>	TYPE	OFF	<input checked="" type="checkbox"/>
		Channel	<input checked="" type="checkbox"/>	Hour and min	<input checked="" type="checkbox"/>	Days of the week	<input checked="" type="checkbox"/>					
		C1	<input checked="" type="checkbox"/>	14.05	<input checked="" type="checkbox"/>	MON...SUN	<input checked="" type="checkbox"/>	P02 OK				

NOTE: To set a self-cleaning cycle you need to edit 2 programs :

P01 - ACTIVATION PROGRAM - **C1 ON**

P02 - SHUTDOWN PROGRAM - **C1 OFF**

DELETE (A - see diagram on page 22)

This option allows for deleting all the operations of the last 40 programs in just one step.

DELETE (B - see diagram on page 22)

Confirming with the button deletes only the selected program.

Since all programs are stored consecutively, deleting one program can change the number assigned to each one of them.

RESET. SET TO ZERO.

Starting on standby mode (main screen), press the **C (7 - see diagram on page 21)** key and while keeping it pressed press the **▼** and **▲** keys simultaneously for more than 3 seconds. The display gets turned off, all programming is deleted.

The device must be powered.

We can also perform a quick deletion that does not affect the programming by pressing the four keys simultaneously (**RESET - see diagram on page 21**).

The device must be powered.

BATTERY REPLACEMENT

The device has a power-reserve of 4 years, by means of a replaceable CR2032 lithium battery

Battery replacement (3) is made by removing the battery holder placed on the front of the device through a flat-head screwdriver (2). Observe the battery polarity as marked on the battery holder. When the battery is dead and the device is powered the battery symbol appears on screen (1).

Note: When changing the battery the device's programming is not lost, and neither is the current time.

TURN OFF THE POWER SUPPLY TO REPLACE THE BATTERY

Legend

1 - battery symbol

2 - battery support

3 - CR2032 lithium battery

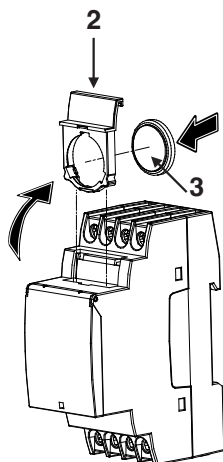
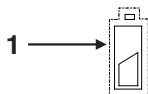

TEST OF THE CENTRAL POWER UNIT - KT10 - KT10A

The general centralised vacuum system test must be done after the final assembly of all vacuum sockets and compensation valve.

1 - Activate the central power unit with all the sockets closed and verify that the pressure on the display does not exceed 250 mBar.

If the value is greater, regulate the compensation valve. so as not to exceed 250 mBar.

If the pressure on the display is too low (below 220 mBar), check the system for leaks. If there are no leaks, regulate the valve until the pressure is 250 mBar.

2 - Insert the hose in the nearest vacuum socket to the central power unit. Check the suction value on the display of the unit: the value must be between 90 and 160 mBar. If the value is within the range continue with step 3.

If the value is lower than the range check for leaks in the system.

If the value is greater than the range check for any blocks in the system.

If the problem is not solved, contact the Aertecnica Service Centre.

3 - Insert the hose in the furthest vacuum socket from the central power unit. Check the vacuum value on the display of the unit: the value must be between 90 and 160 mBar: if the value is within the range, the test of the KT10 - KT10A central power units has ended positively.

If the value is lower than the range check for leaks in the system.

If the value is greater than the range check for any blocks in the system.

If the problem is not solved, contact the Service Centre.

NOTE: To verify that the electrical connection of the vacuum sockets is operating properly, activate the vacuum system from each outlet.

TEST OF THE CENTRAL POWER UNITS - KT20 - KT20A - KT20M - KT20MA - KT30 - KT30A

The general test for the centralised vacuum system must be done after the final assembly of all the vacuum sockets.

1 - Activate the central power unit with all sockets closed and wait a few seconds: check that the pressure on the display is equal to 160 mBar (for KT20A and KT30A).

If the value is lower check for leaks in the system.

If the value is higher contact the Service Centre.

2 - Insert the hose in the nearest vacuum socket and subsequently in the furthest from the central. Verify on the display of the unit that in both cases the value of the intake is not lower than 140 mBar. If the value is higher, continue with step 3.

If the value is lower than 140 mBar check for any leaks in the system.

3 - insert two hoses simultaneously in two vacuum sockets placed in different areas of the building. (for KT30 e KT30A models inserting three flexible hoses). Verify on the display of the unit that the value of the intake is not lower than 100 mBar. If the value is higher, the test is successfully completed.

If the value is lower than 100 mBar check for any leaks in the system.

NOTE: To verify that the electrical connection of the vacuum sockets is operating properly, activate the vacuum system from each outlet.

FAULT REPORTS AND SOLUTIONS

Kompakte KT power units with Inverter: KT20 - KT20A - KT20M - KT20MA - KT30 - KT30A

Fault code	Fault type	Cause	Solutions
E4	Overcurrent during ACC	ACC time too short.	Increase the ACC time, or reduce the software current limit point through P11.06; if the process requires rapid ACC, increase the inverter (VFD) capacity.
		Load too large or sudden change of load.	Increase the inverter (VFD) capacity to ensure that the motor does not experience stalling, and that the load equipment functions without any exception.
		Start during motor rotating.	Start after the motor stops, or select speed tracking start through P01.00.
		3PH output current imbalance.	Check the inverter (VFD) output voltage and motor resistance to ensure three-phase balance.
		When sensorless vector control is used for motor control, parameter autotuning is not performed.	Set the rated parameters according to the motor nameplate, and perform parameter autotuning through P00.15.
		When V/F control is used for motor control, V/F curve setting is abnormal.	Adjust the frequency and voltage relationship set by the V/Fcurve, and reduce the voltage corresponding to the frequency.
		There are strong external interference sources (contactor switchover or improper grounding).	To avoid strong interference keep the motor cables away from contactors and ensure reliable grounding of the system.
		Grid voltage is too low.	Improve the power quality, or increase the inverter (VFD) capacity.
E5	Overcurrent during DEC	DEC time too short.	Increase the DEC time, or reduce the software current limit point through P11.06; if the process requires rapid DEC, increase the inverter (VFD) capacity..
		Software current limit point setting too high.	
		Load too large or sudden	

Fault code	Fault type	Cause	Solution
E5	Overcurrent during DEC	3PH output current imbalance.	Reduce the software current limit point through P11.06.
		When sensorless vector control is used for motor control, parameter autotuning is not performed.	Increase the VFD capacity to ensure that the motor does not experience stalling, and that the load equipment functions without any exception.
		When V/F control is used for motor control, V/F curve setting is abnormal.	Check the VFD output voltage and motor resistance to ensure three-phase balance.
		There are strong external interference sources (contactor switchover or improper grounding).	Set the rated parameters according to the motor nameplate, and perform parameter autotuning through P00.15.
		Hardware fault.	Adjust the frequency and voltage relationship set by the V/F curve, and reduce the voltage corresponding to the frequency.
			To avoid strong interference, keep the motor cables away from contactors and ensure reliable grounding of the system.
Replace the VFD.			
E6		Load too large or sudden change of load.	Increase the VFD capacity to ensure that the motor does not experience stalling, and that the load equipment functions without any exception.
		Software current limit point setting too high.	Reduce the software current limit point through P11.06.

Fault code	Fault type	Cause	Solution
E6	Overcurrent during constant speed running	Load too large or sudden change of load.	Increase the VFD capacity to ensure that the motor does not experience stalling, and that the load equipment functions without any exception.
		Software current limit point setting too high.	Reduce the software current limit point through P11.06.
		3PH output current imbalance.	Check the inverter (VFD) output voltage and motor resistance to ensure three-phase balance.
		When sensorless vector control is used for motor control, parameter autotuning is not performed.	Set the rated parameters according to the motor nameplate, and perform parameter autotuning through P00.15.
		When V/F control is used for motor control, V/F curve setting is abnormal.	
		There are strong external interference sources (contactor switchover or improper grounding).	To avoid strong interference, keep the motor cables away from contactors and ensure reliable grounding of the system.
		Grid voltage is too low.	Improve the power quality, or increase the inverter (VFD) capacity.
		Hardware fault.	Replace the VFD.

Fault code	Fault type	Cause	Solution
E7	Overvoltage during ACC	ACC time too short.	Increase the ACC time or enable overvoltage stall protection.
		Grid voltage too high.	Improve the power quality to comply with the VFD input voltage specifications (refer to product specifications).
		Start during motor rotating.	Start after the motor stops, or select speed tracking start through P01.00.
		Load energy regeneration is too large.	Install a braking unit and energy feedback unit, or remove external factors that cause the load to generate power.
		Improper setting of overvoltage stall protection.	Enable overvoltage stall protection through P11.03, and lower the overvoltage stall protection
E8	Overcurrent during ACC	Deceleration time too short.	Increase the DEC time; if the process requires rapid DEC, braking units, energy feedback units can be added, or the magnetic flux braking function can be used.
		Grid voltage too high	Improve the power quality to comply with the VFD input voltage specifications (refer to product specifications).
		Load energy regeneration is too large.	Install a braking unit and energy feedback unit, or remove external factors that cause the load to generate power.
		Improper setting of overvoltage stall protection.	Enable overvoltage stall protection through P11.03, and over the overvoltage stall protection voltage value of P11.04.

Fault code	Fault type	Cause	Solution
E9	Overvoltage during constant speed running	Grid voltage too high.	Improve the power quality to comply with the VFD input voltage specifications (refer to product specifications). ☒ Install a braking unit and energy
		Load energy regeneration is too large.	Install a braking unit and energy feedback unit, or remove external factors that cause the load to generate power.
		Improper setting of overvoltage stall protection.	Enable overvoltage stall protection through P11.03, and lower the overvoltage stall protection voltage value of P11.04.
E10	DC bus undervoltage	Grid voltage is too low.	Increase the mains input voltage.
		Abnormal bus voltage display.	Contact us.
		Abnormal precharge contactor closing.	Contact us.
		Running under heavy load in the event of input phase loss.	Verificare la presenza di alimentazione in ingresso anomala e cavi di ingresso allentati.
E11	DC bus undervoltage	Grid voltage is too low.	Increase grid input voltage.
		Motor rated current is set incorrectly.	Reset the motor rated current in the motor parameter group.
		Motor stall or load jumps violently.	Check the load and adjust torque boost.

Fault code	Fault type	Cause	Solution
E12	VFD overload	ACC is too fast.	Increase ACC time.
		The motor is restarted during rotating.	Avoid restart after stop.
		Grid voltage is too low.	Increase grid input voltage.
		Load is too heavy.	
		VFD power is too small.	Select a VFD with larger power.
E13	Input side phase loss	Phase loss or significant fluctuations in input L1, L2, or L3.	Check for abnormal input power and loose input cables.
		Input-side screws are loose.	Set P11.00 to screen out the fault.
E14	Output side phase loss	Output cables are broken or short connected to the ground.	Check for loose or broken output cables
		UVW phase loss (or the three phases of load are seriously asymmetrical).	Check for sharp load fluctuation and motor 3PH resistance imbalance.
		Note: The output phase loss detection time requires at least 2.5s. After phase loss, instability may occur, potentially triggering overcurrent overvoltage, overload, and speed deviation faults.	
E16	Inverter module overheat	Air duct is blocked or fan is damaged.	Ventilate the air duct or replace the fan.
		Ambient temperature is too high.	Keep good ventilation to lower ambient temperature.
		Long-time overload running.	Select a VFD with larger power.

Fault code	Fault type	Cause	Solution
E17	External fault	DI terminal external fault input signal acted.	Check whether external device input is normal.
E18	Modbus/ Modbus TCP communication fault	Incorrect baud rate	Set a proper baud rate.
		Communication line fault.	Check the communication por wiring.
		Incorrect communication address.	Set the communication address correctly.
		Communication suffers from strong interference	You are recommended to use shielded cables to improve anti-interference.
E19	Current detection fault	Abnormal motor cable or motor insulation.	Remove motor cables to check.
			Contact us.
E20	Motor autotuning fault	Motor capacity does not match with the VFD capacity. This fault may occur if the capacity difference exceeds five power classes.	Change the VFD model, or adopt V/F mode for control
		Incorrect motor parameter setting.	Check motor wiring, motor type, and parameter settings.
		The parameters gained from autotuning deviate sharply from the standard parameters.	Empty the motor load and re-perform autotuning.
		Autotuning timeout.	Check whether the upper limit frequency is larger than 2/3 of the rated frequency.
		Pulse current setting is too large.	Decrease the pulse current setting properly.

Fault code	Fault type	Cause	Solution
E21	EEPROM operation fault	Error in reading or writing control parameters	Press STOP/RST to reset.
		EEPROM damaged.	Replace the control board.
E22	PID feedback offline.	PID feedback offline.	Check PID feedback signal wires.
		PID feedback source disappears.	Check PID feedback source.
E23	Braking unit fault	Fault occurred to the braking circuit or the braking pipe is damaged.	Check the braking unit, and replace with new braking pipe
		External braking resistor with small resistance.	Increase the braking resistance.
E24	Running time reached	Actual VFD running time longer than internally set running time.	Contact us.
E25	Electronic overload	The VFD reports the overload alarm according to the setting.	Check whether the overload alarm point is set properly.
E27	Parameter upload error	Keypad cable connected improperly or disconnected.	Check the keypad cable and re-plug to determine whether a fault occurs.
		Keypad cable too long, causing strong interference.	Check the surroundings to rule out interference source
		Keypad or mainboard communication circuit error.	Replace the hardware and seek maintenance services.
E28	Parameter download error	Keypad cable connected improperly or disconnected.	Check the surroundings to rule out interference source
		Keypad cable too long, causing strong interference.	Replace the hardware and seek maintenance services.
		Keypad data storage error	Check whether the version of the control board software of keypad backup parameter copy is the same as the version of the control board software of the VFD

Fault code	Fault type	Cause	Solution
E30	Ethernet communication fault	No data transmission between the communication card and the host controller (or PLC).	Check whether the communication card wiring is loose or dropped.
E32	To-ground short-circuit fault	The output of the VFD is short circuited to the ground.	Check whether the motor is short circuited to the ground and wiring is normal.
		Current detection circuit fault.	Check whether the motor wiring is normal.
			Replace the main control board.
		Actual motor power setup deviates sharply from the VFD power.	Reset the motor parameters properly.
E34	Speed deviation fault	Load too heavy or stalled.	Check for overload, increase speed deviation detection time, or prolong ACC/DEC time.
			Check motor parameter settings and re-perform motor parameter autotuning.
			Check speed loop control parameter settings.
E35	Mal-adjustment fault	Load exception.	Check for overload or stalling.
		Incorrect SM parameter settings.	Check motor parameter and counter EMF settings.
		Autotuned motor parameters are inaccurate.	Re-perform motor parameter autotuning.
		The VFD is not connected to the motor.	Increase the maladjustment detection time.
		Flux weakening application	Adjust flux weakening coefficient and current loop parameters.

Fault code	Fault type	Cause	Solution
E36	Underload fault	The VFD reports the underload alarm according to the setting.	Check the load and overload alarm thresholds.
E40	Safe torque off	Safe torque off function is enabled by external forces.	
E41	Safety circuit exception of STO channel 1	The wiring of STO is improper	Check whether terminal wiring of STO is proper and firm enough.
		Fault occurred to external switch of STO.	Check whether the external switch of STO can work properly
E42	Safety circuit exception of STO channel 2	Channel safety circuit hardware fault.	Replace the control board.
Note: Re-power on is required to remove the fault.			
E43	Exception to both STO channel 1 and channel 2.	Hardware fault occurred to STO circuit.	Replace the control board.
E44	STO safety code FLASH CRC heck fault	Drive board fault.	Replace the control board.
E57	PROFINET	No data transmission between the communication card and the host controller (or PLC).	Check whether the communication card wiring is loose or dropped.
E59	Motor overtemperature fault	Equipment or ambient temperature too high.	Lower the equipment or ambient temperature.
		AI/AO detected temperature inaccurate.	Replace the temperature measuring resistor.
		DI4 input motor overtemperature signal.	Check the external temperature measuring terminal signal.

Fault code	Fault type	Cause	Solution
E60	Communication card identifying failure	There is data transmission in communication card interface, but the card type cannot be identified.	Check whether the expansion card in the slot is supported.
			Stabilize the expansion card interface after power-off, and check whether the fault persists at next power-on.
E63	Communication card communication timeout fault	No data transmission in the communication card interface.	Check whether the insertion port or card slot is damaged. If yes, replace the insertion port or card slot after power-off.
E66	EtherCAT communication timeout	No data transmission between the communication card and the host controller (or PLC).	Check whether the communication card wiring is loose or dropped.
E92	A11 disconnection	AI1 input too low.	Connect a 5V or 10mA power source to check whether the input is normal.
		☒ AI1 wiring disconnected.	Check the wiring or replace the cable.
E93	A12 disconnection	AI2 input too low	Connect a 5V or 10mA power source to check whether the input is normal.
		☒ AI2 wiring disconnected.	Check the wiring or replace the cable.
E94	A13 disconnection	AI3 input too low	Connect a 5V or 10mA power source to check whether the input is normal.
		☒ AI3 wiring disconnected.	Check the wiring or replace the cable.

ORDINARY MAINTENANCE

ORDINARY MAINTENANCE

Careful maintenance prolongs the life-time of the central power unit and guarantees better performance.



Before starting with any maintenance operation, disconnect the central power unit from the power supply.



Do not insert your upper limbs inside the unhooking/hooks mechanism of the dust container.

DUST CONTAINER OPENING

Turn the special handle (L) upwards and remove the dust container using the carrying handle (M).

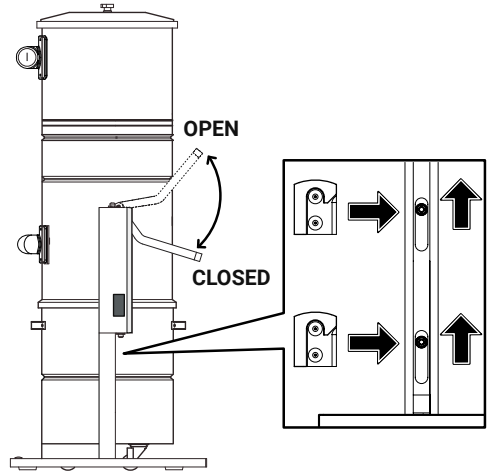
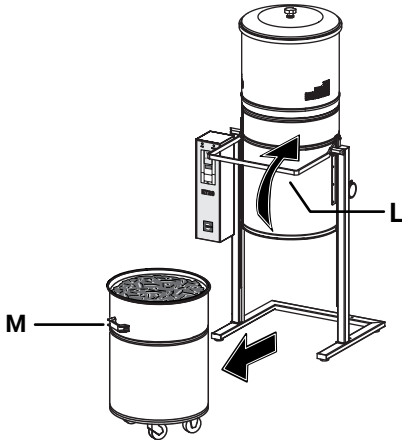

DUST CONTAINER CLOSING

Inserire il contenitore all'interno del telaio in modo che i due ganci (S) del contenitore vadano in battuta sui due perni (P) sul lato sx e dx del telaio.

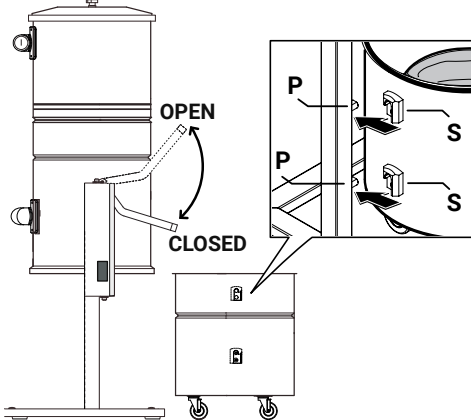

Turn the handle (L) downwards at the end of use. The coupling mechanism raises and closes the dust container.

DUST CONTAINER EMPTYING

We recommend that you replace the bag before it reaches its maximum capacity.

- 1 - open the power unit by turning the handle (L) upwards and remove the dust container by sliding it on the 4 wheels.
- 2 - remove the conveyor cone (N)

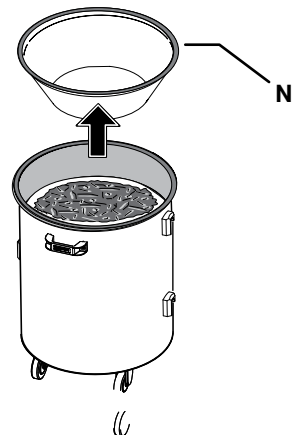

3 - Remove the bag tensioner (Q), remove the full bag (S), close it and throw it in the waste according to current environmental regulations.

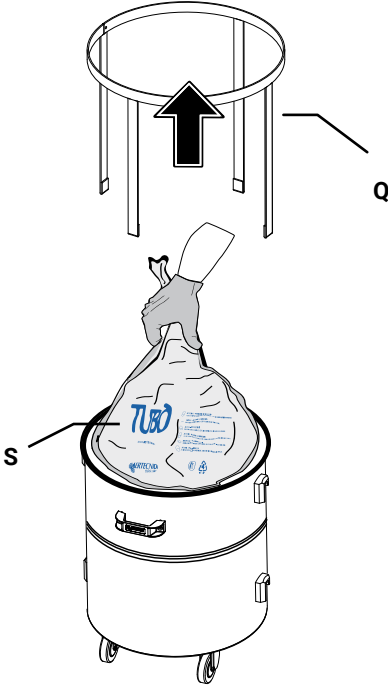

5 - reinsert the conveyor cone making sure that the rubber seal (O) is in the correct position.

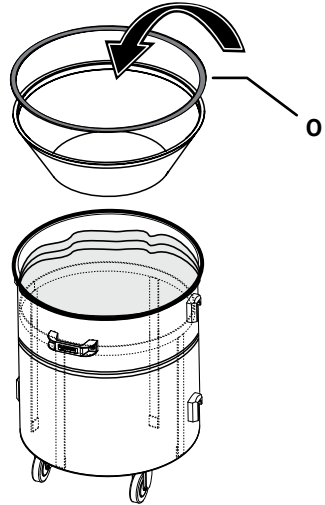

4 - insert a new dust bag into the container and insert the bag tensioner inside the bag.



6 - reinsert the dust container using the carrying handle (M) and close the unit by turning the handle (L) to the bottom.

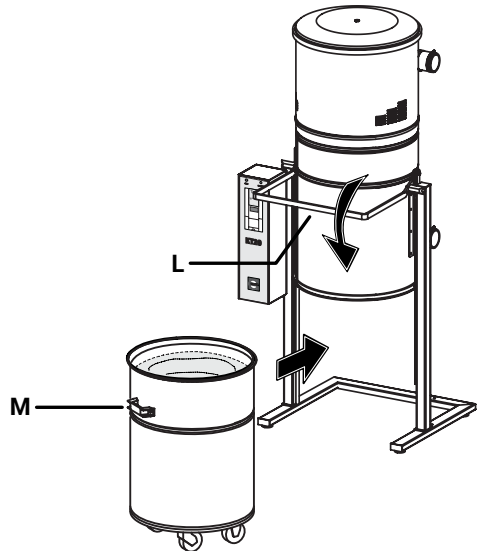



FILTER CARTRIDGE REPLACEMENT

 Before starting with any maintenance operation, disconnect the central power unit from the power supply.

We recommend that you replace the filter cartridge every 2-3 years.

This period may change depending on the degree of system use.

ATTENTION



 When replacing the filter cartridge, it is easy to come into contact with the dust collected by the unit. Before removing the filter cartridge, we recommend that you put on personal protective garments.

 The central power unit must not be put into operation without a filter cartridge placed inside it. Failure to observe this rule could cause damage to the motor that is not covered by the warranty.

 Do not insert your upper limbs inside the unhooking/hooks mechanism of the dust container.

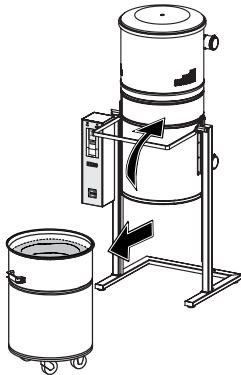
1 - Open the central power unit and remove the dust container.



2 - Unscrew the knob (P) that fastens the cartridge and remove it from its housing.

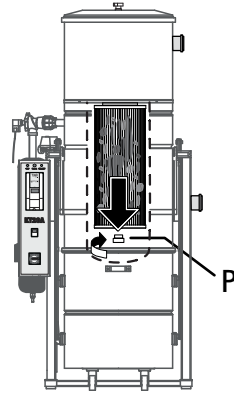

3 - Insert a new cartridge and tighten the knob completely.

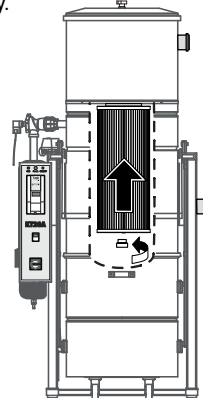

4 - Put the dust container back and close the unit.

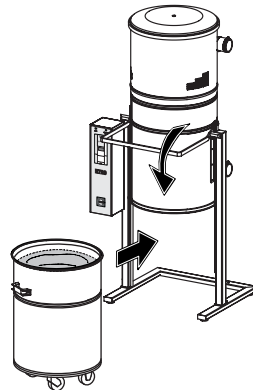

FILTER CARTRIDGE REGENERATION

Periodic filter cartridge regeneration improves overall centralised vacuum system productivity.

ATTENTION

To effectively regenerate the saturated cartridge and keep the centralised vacuum system operating, we recommend that you insert a new filter cartridge immediately, restart the system and vacuum the largest dust particles from the saturated cartridge using the system itself.

ATTENTION



When regenerating the filter cartridge, it is easy to come into contact with the dust collected by the unit.



Before removing the filter cartridge, we recommend that you put on personal protective garments.



ATTENTION

CARTRIDGE GASKET CHECK

Check the gasket condition (G) of the filter cartridge. Replace if damaged.

1 - Vacuum the dust collected on the saturated cartridge walls using the system itself.

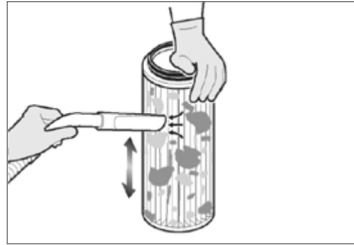

2 - After an initial brief cleaning, wash the filtercartridge with a jet of water that is not too strong and remove the dust that has penetrated between the walls.

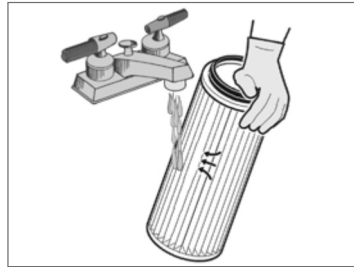

3 - Allow the cartridge to dry completely and check the gasket condition (G)

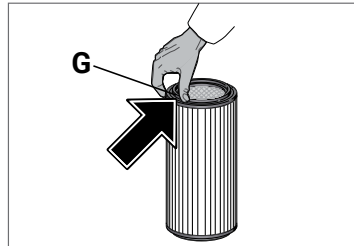

4 - Make sure that there are no tears or cuts on the cartridge walls. If there are, the damaged cartridge must be replaced with a new one.

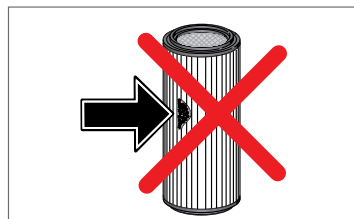

UNIT DISPOSAL

At the end of its life cycle, the machine must be disposed of in compliance with current applicable regulations.

The following table specifies the material with which the central power unit is built.



IMPORTANT

The materials listed below must be divided and stored to be recycled or disposed of in compliance with the environmental regulations valid in the country of use.

TYPE OF MATERIAL	PRESENCE IN	SPECIFICATION	FOR DISPOSAL
PLASTIC AND RUBBER	openings	polypropylene	<p>The regulations that govern the disposal and demolition of the central power unit, its components and the possible polluting material and substances change depending on the country of final use.</p> <p>We recommend that you contact the authorised organisations and agencies and respect the current applicable legal regulations</p>
	cone seals and cables	PVC	
	cable gland	polyamide fibre	
	filter cartridge	polyester	
	rubber sleeves	SBR/NR rubber	
	clamps	nylon	
	stickers	PVC	
	container handle	nylon	
	feet of frame stand	megol synthetic rubber	
	caps for frame columns	PVC	
	pressure switch and vacuum gauge	ABS	
	filter knob	polyamide fibre	
	compressed air hoses	PVC	
	silencer	polystyrene	
GALVANIZED COMPONENTS	screws and rivets	steel/brass	
ELECTRONIC COMPONENTS	electronic card	electric parts	
	Inverter	electric parts	
	compressor motor	electric parts	
	electrical wires	copper	
	schuko plug	polyamide	
SHEET METAL	dome	painted steel	
	command panel box	painted steel	
	central body	painted steel	
	dust container	painted steel	
	self-cleaning tank	painted steel	
	opening/closing lever	painted steel	
PACKAGING	box	cardboard	
	interlayers	cardboard	
	pallet	wood	
	bags	polyethylene	

TROUBLESHOOTING

The table shows generic cases of malfunctions or failures that may occur during the normal life-cycle of the vacuum cleaner unit. Follow the instructions shown.

PROBLEM	CAUSE	ACTION
MOTOR DOESN'T TURN	inverter damaged	call in the assistance centre
	the wiring of the cables is not correct	call in the assistance centre
	motor burned out	call in the assistance centre
	no power supply	make sure that the electric line is dimensioned to support the central power unit electrical power
MOTOR GET OVERHEATS	the motor draws excess current	Ridurre la pressione di lavoro allentando la valvola rompivuoto
	there is insufficient ventilation in the technical room where the central power unit is installed	the turbine has been designed to run at room temperatures from -15°C to +40°C
MOTOR DOESN'T RUN REGULARLY	turbine seized	call in the assistance centre
	there is no air from the motor air intakes	clean the motor air intakes that prevent the necessary passage of air
MAIN SWITCH TRIPS FREQUENTLY	there is insufficient ventilation in the technical room where the central power unit is installed	the turbine has been designed to run at room temperatures from -15°C to +40°C
SELF-CLEANING DOESN'T WORK	compressor damaged	call in the assistance centre
	protective fuse burnt out	call in the assistance centre
For other causes that are not covered in this manual call a specialised technician		



EN

The descriptions and illustrations may change. Aertecnica SpA reserves the right to modify the product and the related technical documentation without incurring any obligation to third parties.

AERTECNICA S.p.A.

Via Cerchia di Sant'Egidio, 760 - 47521 Cesena (FC) - ITALY

Tel. +39 0547 637311

info@aertecnica.com

www.aertecnica.com

9000527/1_rev. 26

