

X-PERT SMART

CENTRAL POWER UNITS

MODELS: RT1AS
RT2MAS
RT2AS
RT3AS

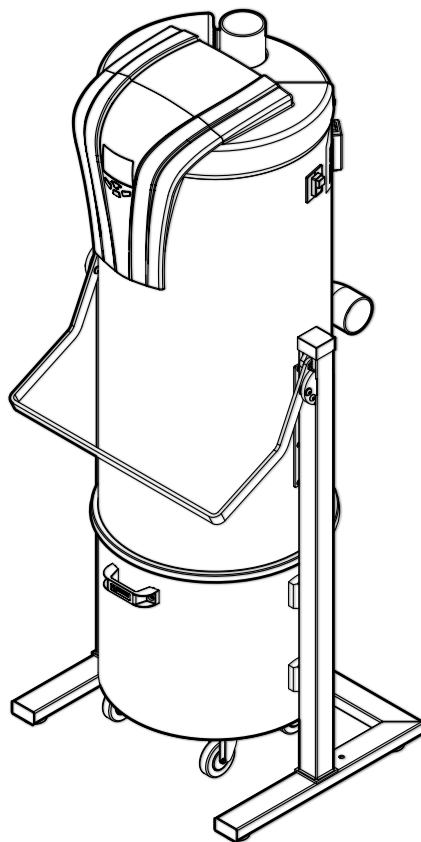

EN

Version translated from the original

INDEX

GENERAL INFORMATION

- 3 EU Declaration of Conformity
- 4 General warnings
- 4 Warranty
- 5 Safety
- 5 Manufacturer
- 5 Technical assistance
- 6 Identification plate
- 7 Technical data
- 8 Description of parts
- 9 Intended use
- 9 Incorrected use
- 9 Operator

ORDINARY MAINTENANCE

- 23 Emptying the container
- 25 Filter cartridge replacement
- 26 Filter cartridge regeneration
- 27 Unit disposal
- 28 Troubleshooting

INSTALLATION

- 10 Transport
- 10 Installation local
- 10 Placing
- 11 Unit installation measurements
- 12 Inlet line connection dust
- 13 Compensation valve installation
- 14 Exhaust line connection
- 15 Electric connection
- 16 X-PERT SMART starting/shutting down
- 17 Wi-Fi connection
- 18 Led display panel operation
- 20 Table of anomalies and locks
- 21 APF self-cleaning system
- 22 X-PERT SMART Unit testing

EC CONFORMITY DECLARATION OF A MACHINE



The manufacturer AERTECNICA. S.P.A declares under its own responsibility that the product:

SERIES: X-PERT SMART CENTRAL POWER UNIT

MODELS: RT1AS / RT2MAS / RT2AS / RT3AS

COMPLIES WITH

to the essential health and safety requirements established by the following Directives:
The Directive 2006/42/EC (Machinery directive) and subsequent amendments and additions.

The Directive 2014/30/UE (EMC directive) and subsequent amendments and additions.

The Directive RoHS III 2011/65/UE (Dangerous substances and limits) and subsequent amendments and additions.

APPLIED HARMONIZED STANDARDS:

EN ISO 12100:2010

IEC 60335-1:2012 + A11:2014, A13:2017, A1:2019, A14:2019, A2:2019, A15:2021

IEC 60335-2-69:2012

EN 62233:2008

EN IEC 61000-6-2:2019

EN IEC 61000-6-4:2019

EN IEC 61000-3-2:2019 + A1:2021

EN 61000-3-3:2013 + A1:2019 + A2:2021

The declarant

Daniele Golinucci



CESENA, li 14/10/2025

GENERAL INFORMATION

GENERAL WARNINGS

Carefully read the manual

The installation, user and maintenance manual is an integral and essential part of the central power unit and must be read carefully as it contains important information concerning operator safety, foreseen operation and the correct maintenance of the central power unit.

LIABILITY

The central power unit must only be implemented for the use for which it was explicitly designed (see paragraph INTENDED USE).

Any other use is considered incorrect and therefore dangerous (see paragraph INCORRECT USE).

The central power unit should not be used by people with reduced physical, sensorial or mental capacities, by children or by people without product experience or knowledge, unless they are supervised or have been instructed in the use of the central power unit by a person responsible for their safety.

The manufacturer shall not accept any contractual and extra contractual liability due to damage caused by errors in using and installing the central power unit or due to failure to observe the instructions provided by the manufacturer.

ATTENTION

AERTECNICA reserves the right to modify the product and the related technical documentation without incurring any obligation towards third parties.

No part of this manual may be reproduced, copied or distributed in any manner without written authorisation from Aertecnica.

WARRANTY

Warranty conditions for the European Union

Aertecnica ensures the correct operation of the purchased central power unit for a period of 24 months from the documented date of purchase.

If there is no documentation that proves the purchase date (invoice or tax receipt), the 24-month period will refer to the date it was sold by AERTECNICA.

Any additional warranty conditions will be exclusively charged to those who offer them.

For any dispute, the Court of Forlì-Cesena (ITALY) shall have exclusive jurisdiction and Italian law will apply.

Warranty conditions outside the European Union

For countries outside of the European Union the guarantee shall be borne by the importing company and the warranty conditions are those provided by the law of the country where the product is imported to.

SAFETY

The operator must accurately comply with the operating instructions shown by the pictograms in order to guarantee the safety of persons and correct operation of the central power unit.



DANGER: this indicates that attention must be paid in order to prevent events that could cause serious accidents that may harm people or their health.



ELECTRICAL DANGER: make sure that the central power unit is connected with the relative cable to a standard compliant earthing system.

The electricity mains and relevant socket must be appropriate to the rated power of the central power unit. For outdoor installations, the power socket must have an appropriate proper IP protection.



RISK OF CRUSHING: during handling and installation phases of the central power unit, we recommend the use of suitable means for lifting and carrying out the installation as described, in order to avoid the unit accidentally falling.



Do not insert your upper limbs inside the unhooking/hooking mechanism of the dust container.



DANGER OF DAMAGING THE UNIT: follow the use instructions in order to avoid consequences which may lead to damage of the unit.



INHALATION OF HARMFUL ELEMENTS AND DUST: protect respiratory organs by using protective masks when emptying the dust containers and when replacing the filter cartridge so the collected dust is not inhaled.



SENSIVITY TO DUST: this means that hand protection must be used to prevent any harm to operators who are sensitive to the collected dust.

CERTIFICATIONS

Aertecnica S.p.A is a company certified with:



Quality system UNI EN ISO 9001

IDENTIFICATION

This user and maintenance manual refers to the following models of the Central power unit:

SERIES: X-PERT SMART

MODELS: RT1AS / RT2MAS / RT2AS / RT3AS

MANUFACTURER

AERTECNICA S.p.A.

Via Cerchia di Sant'Egidio, 760

47521 Cesena (FC) ITALY

Tel. +39 0547/637311

info@aertecnica.com

www.aertecnica.com

TECHNICAL SERVICE

The Technical Service Centre can be contacted for all technical problems and if spare parts are needed. For all communications concerning the central power unit, the user should always provide the following data:

model of the central power unit

serial number

year of manufacture

purchase date and detailed information about the issues found.

IDENTIFICATION PLATE

For these models, the identification plate is located on the body of the central power unit as shown in the figure.

The necessary identification data:
model of the central power unit
serial number
year of manufacture.

TUBO by AERTECNICA <small>think clean</small>		CE		Aertecnica S.p.A. via Cerchia di S. Egidio 760 47521 Cesena - FC ITALY	
Model	<input type="text"/>	Serial n°	<input type="text"/>		
Voltage	<input type="text"/> V	Year	<input type="text"/>		
Absorbed current	<input type="text"/> A	Net weight	<input type="text"/>	kg	
Frequency	<input type="text"/> Hz				
Power	<input type="text"/> W				

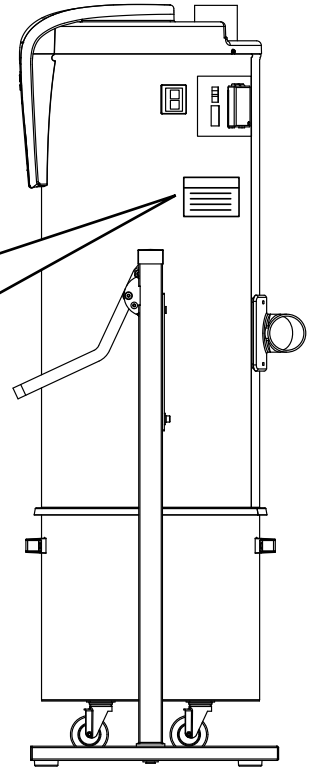

TECHNICAL DATA

Models		RT1AS	RT2MAS	RT2AS	RT3AS
Commercial code		CIRT10AS	CIRT20MAS	CIRT20AS	CIRT30AS
Number of operators at the same time*	n°	1	2	2	3
Max number of Pratico Smarts sockets	n°	15	15	15	15
Number of Traditional sockets	n°	30	40	40	50
Power supply	Volt (Vac)	380/400	220/240	380/400	380/400
Frequency	Hz	50/60	50/60	50/60	50/60
Maximum absorption	A	6,5	19	6,5	8
Motor revolutions	rpm	3.000	3.600	3.900	4.500
Motor power	W	2.200	2.600	3.000	4.800
Turbine stages	n°	1	1	1	1
Suction power	Air Watts	875	1.230	1.440	1.750
Maximum vacuum	mBar	370	370	370	370
Air flow	m ³ /h	348	431	475	535
Inverter	-	No	Yes	Yes	Yes
Soft Start starting	-	No	Yes	Yes	Yes
Power sockets	Volt (Vcc)	12	12	12	12
Self-cleaning sistem	-	Yes	Yes	Yes	Yes
Safety Filter cartridge surface	cm ²	25.000	25.000	25.000	25.000
Safety Filter cartridge material	-	polyester lavable	polyester lavable	polyester lavable	polyester lavable
Dust Container capacity	litres	66	66	66	66
Central unit diameter	cm	46	46	46	46
Central unit height	cm	161	161	161	161
Weight	kg	99	100	100	102
Dust inlet	∅	80	80	80	80
Air expulsion	∅	80	80	80	80
Compensation Valve	-	Yes	-	-	-
Noise	dB	<70	<70	<70	<70
Recommended surface (up to)	m ²	1.500	2.000	2.000	3.000
Led display	-	Yes	Yes	Yes	Yes

* only for traditional vacuum system Ø50

DESCRIPTION OF PARTS

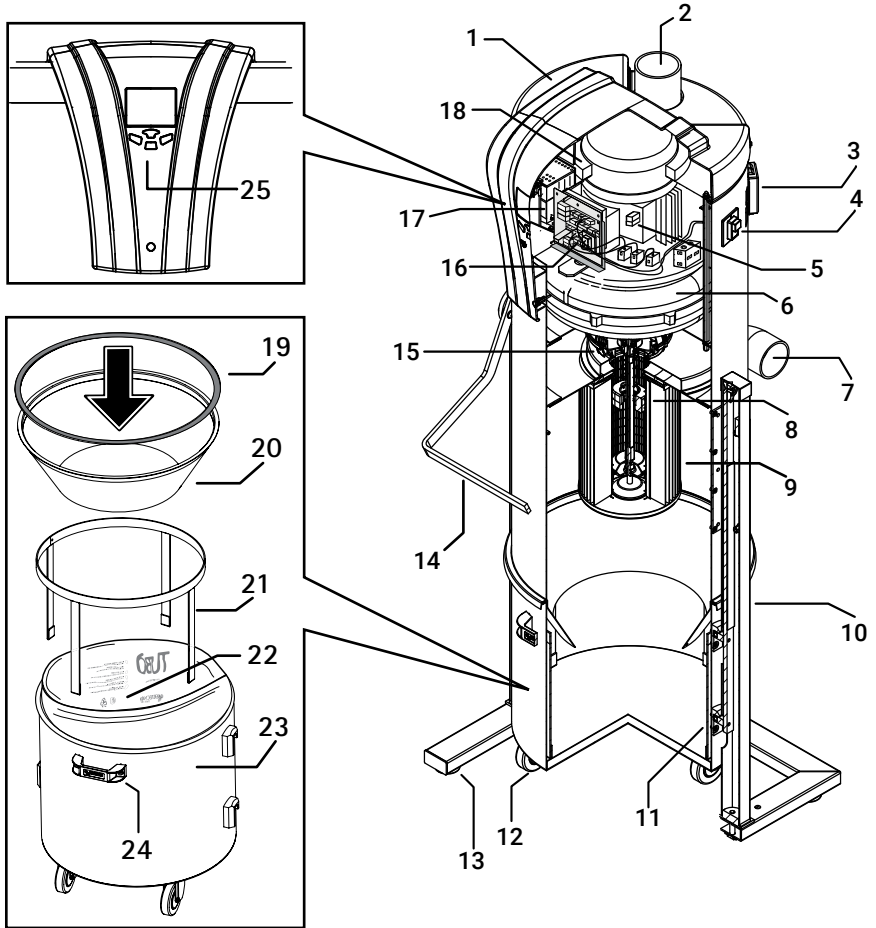

Legend

- | | |
|-----------------------------------------|-----------------------------------------------|
| 1 - dome in thermoplastic material | 13 - anti-vibration |
| 2 - air expulsion | 14 - dust container opening/closing handle |
| 3 - power supply terminal | 15 - APF self-cleaning system |
| 4 - ON/OFF switch | 16 - electronic card |
| 5 - temperature sensor | 17 - inverter (only for RT2MAS, RT2AS, RT3AS) |
| 6 - side channel blower (motor) | 18 - air flow division plate |
| 7 - reversible dust inlet right/left | 19 - cone sealing |
| 8 - beater for self-cleaning cartridge | 20 - deflector cone |
| 9 - polyester filter cartridge | 21 - bag tensioner |
| 10 - support frame | 22 - dust collection bag |
| 11 - coupling system for dust container | 23 - dust container |
| 12 - wheels of the dust container | 24 - carrying handle for dust container |
| | 25 - control keyboard with Led display |

INTENDED USE

The **X-PERT SMART** has been designed **to aspire only class L dust**, including common household dust, earth and lime dust considered to be low toxicity dust.

The dust collection bag must be replaced with a new one every time it fills.

The filter cartridge can be regenerated periodically, and should be changed at least every 2-3 years or immediately in the event of breakage.



Wear personal protective garments before emptying the dust container



or replacing/cleaning the filter cartridge.

INCORRECT USE

In order to guarantee proper operation of the central power unit and to prevent the relative warranty coverage from lapsing, follow the instructions provided below:

- Do not vacuum lighted cigarettes, hot embers or burning material: these materials may cause a fire to start that would damage the hoses and the central power unit.
- Do not vacuum cloths, rags, fabrics or textile material: these materials could obstruct the hoses or damage the central power unit .
- Do not vacuum liquids, materials saturated with liquids or very moist materials: these materials could cause the electric system to short circuit, prevent the proper passage of the dust or damage the sockets and the central power unit.
- Do not allow children to play with the vacuum sockets, opening and closing them continuously or inserting toys or solid items of unsuitable dimensions.
- Do not use the system with the central power unit turned on without the filter cartridge inserted.
- Do not block the air exhaust line.
- Do not block the air sockets for electric motor cooling.
- Do not use the cleaning accessories to vacuum parts of the body.
- Do not leave the central power unit powered when it is not used for prolonged periods of time.

USER

The user must be in good physical and psychological condition.

The user must always be alert during use of the system in order not to trip on the hose or cleaning accessories connected to the system, and must adopt the same safety measures for the persons present in the room with him.

The user must be over the age of 14 years.

INSTALLATION

TRANSPORT

Check the overall mass of the central power unit shown on the identification plate and use the described means for proper handling.

We recommend that you do not remove the packaging until installation so as to prevent any knocks and damage.



Use personal protective equipment during transportation and installation of the unit.

RISK OF CRUSHING



Use a forklift truck during the transport and movement of the central power unit. Proceed at reduced speed, keeping the load at a low level to avoid risks of overturning.



ATTENTION



Packaging parts of the central power unit are inert solid waste that must be disposed of according to current applicable regulations.

MATERIALS	DISPOSAL
ecological cardboard packaging	paper
fir wood ecological pallets	wood
metal carpentry	iron

INSTALLATION LOCATION

The central power unit must be installed in service areas (for example technical compartment, engine room) which are well ventilated and protected from significant temperature changes.

The power supply line of the correct voltage indicated on the unit identification plate, and also the vacuum socket consent line for the activation of the vacuum system, must be set up close to the central power unit.

The installation room must be sufficiently large to allow maintenance work.

The temperature of the installation room must be $0^{\circ} \leq$ room temperature $\leq 35^{\circ}$

The installation room must be sufficiently illuminated (minimum 200 lux) to allow maintenance work.

The installation room must have an air exchange rate per hour ≥ 0.5 v/room (volume/room).

The central power unit must not be placed in an environment classified as ATEX.

POSITIONING

Ensure that the levelling of the floor on which the base of the unit rests is optimal. The floor must have adequate structural strength to support the weight of the unit as shown on the identification plate.

Leave the indicated free space (in cm) around the unit, to allow cleaning and maintenance by the operator.

plan view

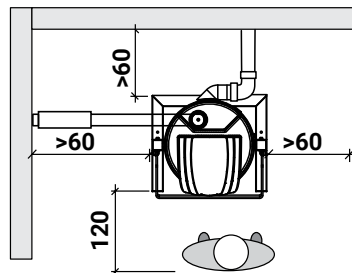

UNIT INSTALLATION MEASUREMENTS

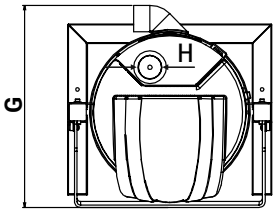
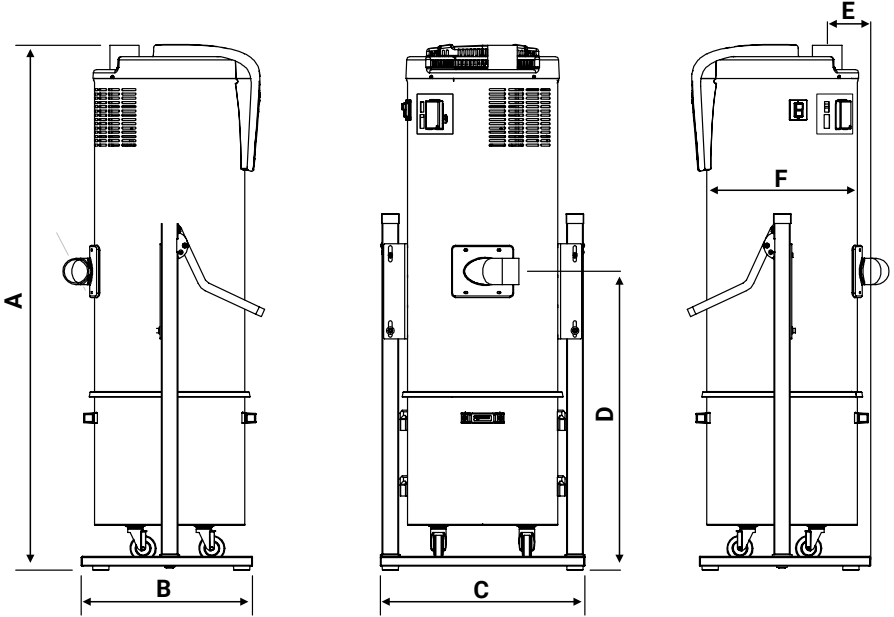

DIMENSIONS (in mm.)

	RT1AS	RT2MAS	RT2AS	RT3AS
A	1.610	1.610	1.610	1.610
B	523	523	523	523
C	624	624	624	624
D	913	913	913	913
E	132	132	132	132
F	460	460	460	460
G	616	616	616	616
H	Ø80	Ø80	Ø80	Ø80

DUST INLET LINE CONNECTION

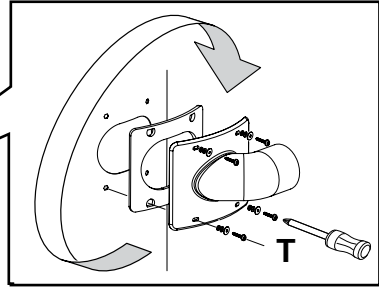
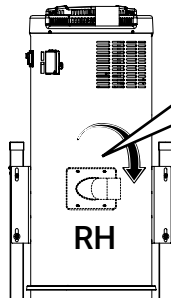
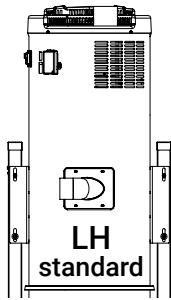

The connection of the central power unit with the dust line is facilitated by the possibility of orienting the inlet opening in two opposite directions, by unscrewing the screws and washers (**T**) and after rotating the opening putting them back the same way, as indicated on the side.

CONNECTION WITH SLEEVE AND CLAMPS

- A - dust inlet opening
- B - clamps
- C - sleeve
- D - dust input pipe line Ø80

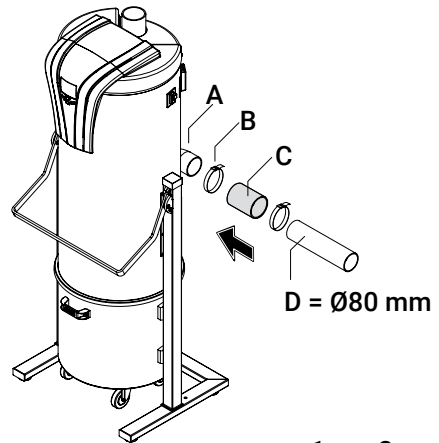

DUST COLLECTOR

The power unit (especially the one for two/three operators) can be connected with more than one dust input line. In this case we recommend that you install a dust collector (**N**).

EXAMPLE OF DUST COLLECTOR

The collector (**N**) receives the different dust lines coming from the power unit. At the base of each dust line, we recommend that you install a special ball valve (**V**) by means of which you can exclude the line from the whole vacuum system of the building.

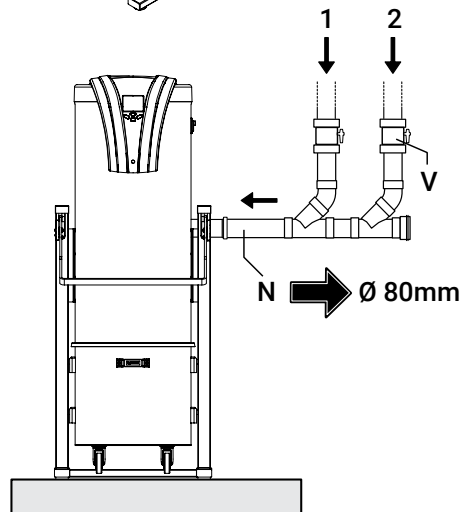

COMPENSATION VALVE INSTALLATION

The compensation valve has the function of regulating the working pressure, and also has a safety function.

In the **RT1AS model**, the compensation valve is supplied with the unit, and is calibrated by the manufacturer to the correct pressure.

COMPENSATION VALVE CONNECTION

K - compensation valve $\varnothing 63M$

J - reduction $\varnothing 80M/\varnothing 63F$

H - curve M/F $\varnothing 80$

G - junction box on dust input line

L - glue for fixing

ONLY FOR RT1AS MODEL

In the RT2MAS, RT2AS and RT3AS models the valve is not present because the pressure is adjusted automatically by the inverter.

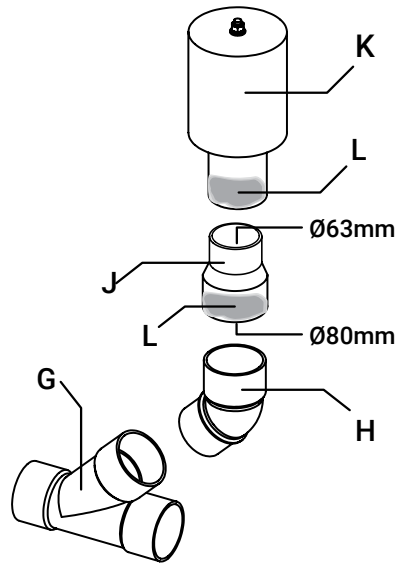

VALVE ORIENTATION

The compensation valve must be installed on the input dust line, which must always be oriented vertically (**V**).

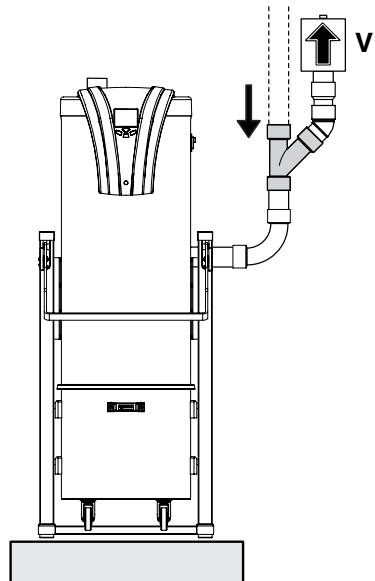
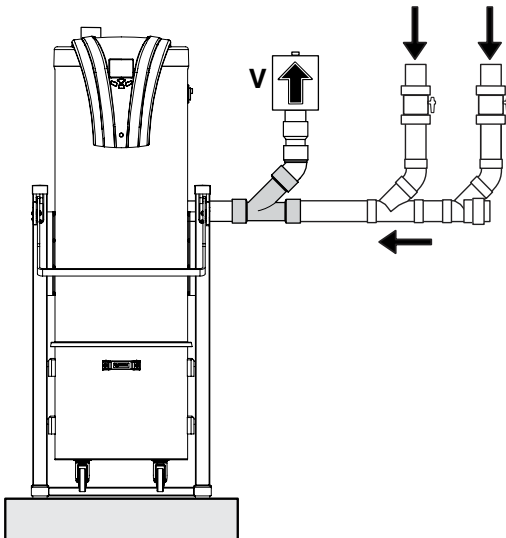

ADJUSTMENT OF THE COMPENSATION VALVE

On the **RT1AS model**, the valve regulation must respect the value indicated in the table

pressure value	250 mbar
----------------	----------

- N** - external fixing nut
- M** - valve protective cover
- P** - internal locknuts
- Q** - adjusting nut

- 1 - unscrew the **(N)** nut and remove the **(M)** cover.
- 2 - press the **START** button and activate the central power unit with all the vacuum sockets closed; check that the value indicated on the display does not exceed 250 mbar.

If the value matches, the valve is calibrated correctly.
 - If the value is greater than the one on the table, rotate the adjustment nut **(Q)** counter clockwise until the value on the table is reached.

- If the value is less than the one on the table, rotate the adjustment nut **(Q)** clockwise until the value on the table is reached.

3 - after making the adjustment, fix the position with the locknuts **(P)**.

Put the protective cover of the valve back on.

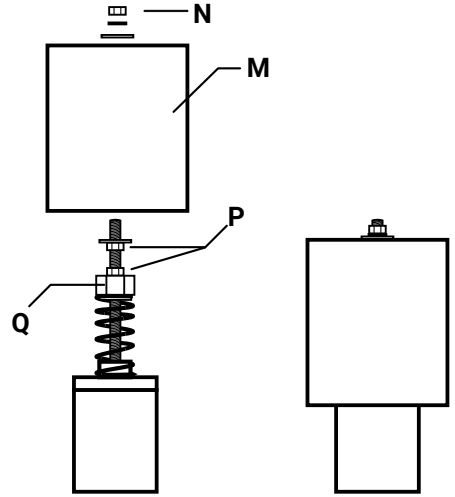

ATTENTION

After finishing the adjustment of that valve, verify that when the central power unit is in operation with all the vacuum sockets closed, the absorption of the central motor does not exceed the maximum value of 6.5A.

AIR EXHAUST LINE CONNECTION

(for all X-PERT SMART models)

Install a $\varnothing 80$ exhaust line pipe that is no longer than 5 metres.

If the exhaust line is longer, use diameter $\varnothing 100$ and mount the silencer of the same diameter.

CONNECTION WITH SLEEVE AND CLAMPS

- E** - air exhaust outlet opening $\varnothing 80$
- F** - air exhaust line pipe
- S** - silencer (not supplied)
- T** - extension
- R** - exhaust grill

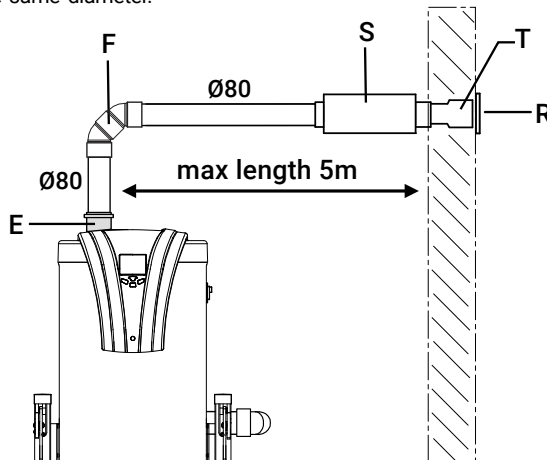

ELECTRICAL CONNECTION

 The electrical system of the central power unit must be made by qualified professionals and in accordance with applicable regulations.

The manufacturer assumes no responsibility for malfunction or damage to persons and/or property resulting from the incorrect connection to the electrical system.

POWER SUPPLY LINE

Make sure that the electric line is dimensioned to support the central power unit electrical power and check that the mains network corresponds to the voltage specified on the identification plate.

CIRCUIT BREAKER

For the RT1AS version, installing a circuit breaker for engine starting.

Differential for RT2MAS, RT2AS, RT3AS

You must connect the power unit to a class B differential for Inverter, not less than 100 mA.

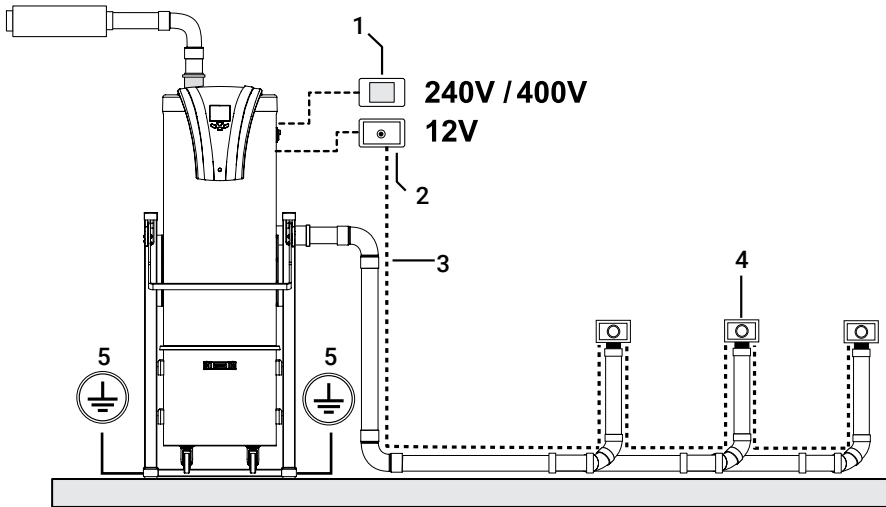

- 1 - main power supply
- 2 - 12V socket line for the activation of the unit
- 3 - pre-wired sheathing 2x1 Ø16 for socket line
- 4 - inlet frames / vacuum sockets
- 5 - earth

RT2MAS

TERMINAL CONNECTION DIAGRAM WITH 240V POWER SUPPLY

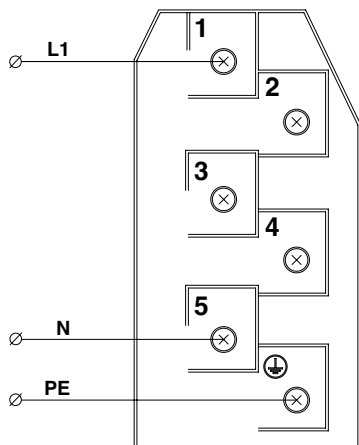

RT1AS - RT2AS - RT3AS

TERMINAL CONNECTION DIAGRAM WITH 400V POWER SUPPLY

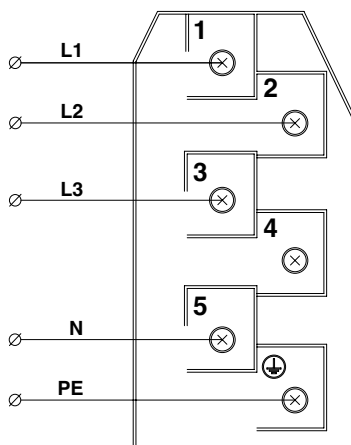

CONNECTION TO VACUUM SOCKETS LINE (LP)

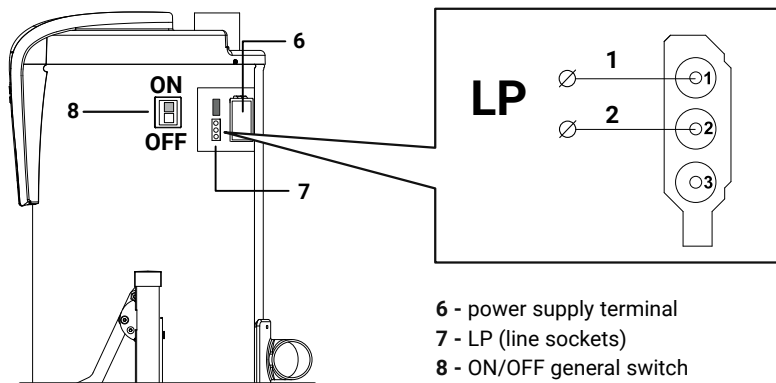

- 6 - power supply terminal
- 7 - LP (line sockets)
- 8 - ON/OFF general switch

X-PERT SMART STARTING

The central vacuum unit starts when it receives the initial consent from the power line (LP) connected to the suction sockets of the vacuum cleaner system, and remains in operation as long as the consent is active.

X-PERT SMART SHUTTING DOWN

The vacuum unit switches off when consent from the power line (LP) is withdrawn.

Wi-Fi CONNECTION

The X-PERT central power unit is equipped with 2.4 Ghz Wi-Fi.

Wi-Fi connection

- 1 - connect the central power unit to the power supply.
- 2 - make sure that the central power unit is placed where there is a good Wi-Fi network reception.
- 3 - download the AERTECNICA DEVICE app and register.
- 4 - collegare il telefono alla rete Wi-Fi e attivare il bluetooth.
- 5 - press and hold the STOP button on the control panel display for 10"; the symbol  starts flashing.
- 6 - from the home page of the app press the + symbol and select "Add device".
- 7 - in the app the central vacuum unit must appear. Select it and follow the instructions in the app.

Once the recognition is complete, on the display of the central vacuum unit will appear the Wi-Fi symbol on 

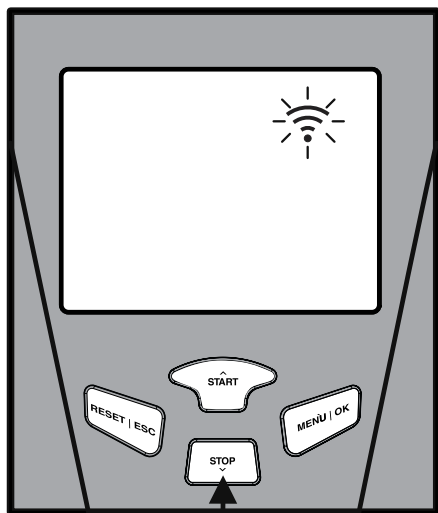

Hold the button for 10 seconds

Wi-Fi STATUS

- symbol on and steady** = Wi-Fi connected
- no symbol** = Wi-Fi not enabled/not connected
- blinking symbol** = Searching Wi-Fi



SCAN THE QR CODE
to access AERTECNICA DEVICE area
dedicated to app for Android
and iOS platforms



The control unit is compatible with
automated systems such as
Amazon Alexa and Google Assistant



ATTENTION

if the control unit does not connect to the Wi-Fi network verify:

A - good reception of the Wi-Fi network:
possibly use extender devices.

B - make sure the bandwidth of the Wi-Fi network
used is set to 2.4GHz.

CONSOLE FEATURES WITH LED DISPLAY

FILLING OF THE DUST CONTAINER

If it is on steadily, it indicates limited remaining capacity. It is recommended to check it and proceed with maintenance.

CONNECT

Indicates that the external electrical activation contacts of the central power unit is active.

FILTER SATURATION

If it is steadily, it indicates that the filter cartridge is saturated. Proceed with maintenance.

Wi-Fi STATUS

symbol on steady = Wi-Fi connected

no symbol = Wi-Fi not enabled or not connected

blinking symbol = searching for Wi-Fi in progress

VACUUM POWER

Displays the vacuum power in mBar.

TEMPERATURE BLOCKAGE

The central vacuum unit signals an overheating of the motor chamber.

RESET | ESC

Press to reset a block or anomaly

MENÚ | OK

Press multiple times to view the different operational parameters.

START ^

Press to activate the central power unit vacuum.

STOP v

Press to turn of the central power unit vacuum. Hold for 10 seconds for Wi-Fi configuration.

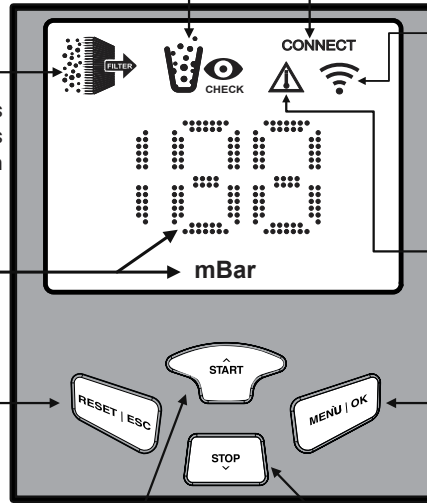

% MAINTENANCE LEVELS / WORKING HOURS

Every time it is switched off, the control unit automatically displays the status:

FILTER SATURATION

100% - CLEAN FILTER

0% - SATURATED FILTER

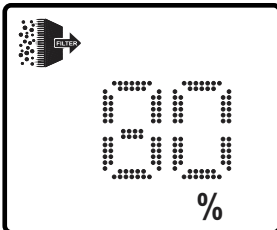

FILLING THE DUST CONTAINER

100% - EMPTY CONTAINER

0% - CONTAINER FULL

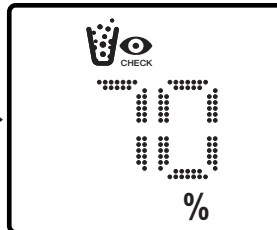

TOTAL WORKING HOURS OF THE CENTRAL POWER UNIT

000 h.

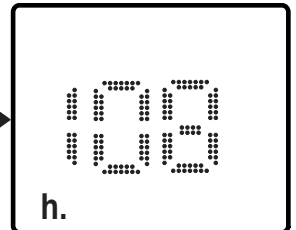

OPERATION PARAMETER DISPLAYS

To exit STAND BY mode, press any button.

While the central power unit is off or in operation, press the MENU/OK key to navigate within the Menu and the operating parameters of the X-PERT central power unit are displayed.

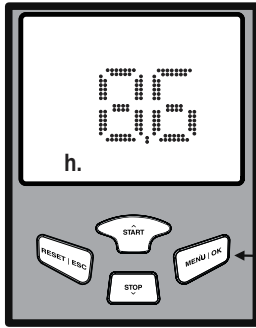

Press the **MENU/OK** key

1 - FILTER EFFICIENCY STATUS

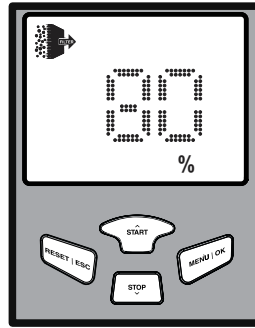

Visualize the filter efficiency as a percentage:
100% - CLEAN FILTER
0% - SATURATED FILTER

After maintenance press the **RESET** key for 2 seconds

2 - DUST CONTAINER FILLING STATUS

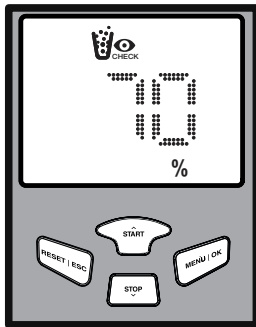

Visualize as a percentage the remaining dust container capacity:
100% - EMPTY CONTAINER
0% - CONTAINER FULL

After maintenance press the **RESET** key for 2 seconds

3 - ENGINE POWER PERCENTAGE

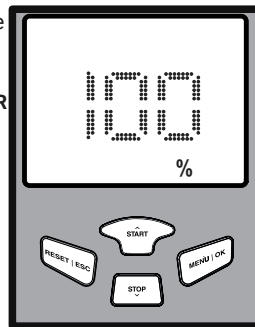

Visualize as a percentage the working power of the motor.

4 - CENTRAL POWER UNIT TEMPERATURE

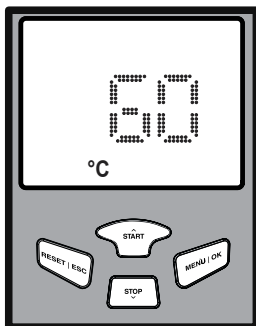

Visualize the temperature of the motor chamber.



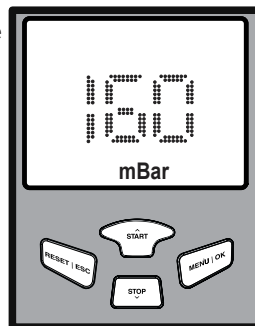



5 - MOTOR VACUUM



Visualize the vacuum power of the motor in mBar.

X-PERT ANOMALY AND LOCK TABLE

The following Anomaly/Operation block statuses may appear on the control unit:

FLASHING ALERT	SIGNAL	NECESSARY MAINTENANCE
 0 % RESET ESC	FILTER CARTRIDGE SATURATION BLOCK	<p>Central power unit displays that the filter is dirty Clean or replace the filter with a new one.</p> <p>For the block reset, press RESET key for 2 seconds.</p>
 0 % RESET ESC	CONTAINER FILLING STATE OR FILTERING BAG	<p>The central power unit displays to check the filling level of the dust container or filtering bag. If it is full, empty the container or replace the collection bag.</p> <p>For the block reset, press RESET key for 2 seconds.</p>
 90 °C	TEMPERATURE BLOCK	<p>The central power unit displays a motor chamber overheating. Wait for it to cool down until the icon lights up</p> <p>RESET/ESC</p> <p>For the block reset, press RESET key for 2 seconds.</p>
 RESET ESC	HIGH DEPRESSION BLOCK	<p>The central power unit displays that the depression/vacuum value is above the standard level. Check for possible obstructions in the suction pipe or scarce air-flow intake.</p> <p>For the block reset, press RESET key for 2 seconds.</p>
 RESET ESC	MAXIMUM OPERATING TIME BLOCK	<p>The central power unit went into block mode because it exceeded the maximum continuous usage time.</p> <p>For the block reset, press RESET key for 2 seconds.</p>
CONNECT RESET ESC	EXCESSIVE STARTUPS BLOCKAGE	<p>The central power unit went into block mode for an excessive number of startups inside 1 minute. Check for any anomalies in the electrical contacts of the vacuuming socket and of the flexible hose.</p> <p>For the block reset, press RESET key for 2 seconds.</p>
 0 mBar	GENERIC FAULT	<p>The control unit won't start; there's a malfunction. Contact the technical support.</p>

APF SELF-CLEANING SYSTEM

The X-PERT SMART is equipped with a self-cleaning system (Aertecnica patent) which, by vibrating the filter, allows dust abatement, extending the regeneration/replacement times of the filter cartridge.

NOTE: it is possible to customize the operation of the self-cleaning by changing the setting of the two switches S1 and S2 as follows:

APF ACTIVATION DELAY (S1 SWITCH)

The activation delay can be changed using the **S1**:

0 = disabled	6 = 60 minutes
1 = 1 minute delay	7 = 70 minutes
2 = 20 minutes	8 = 80 minutes
3 = 30 minutes delay (default value)	9 = 90 minutes
4 = 40 minutes	10 = 100 minute delay
5 = 50 minutes	

SELF-CLEANING CYCLE DURATION (SWITCH S2)

The duration of the self-cleaning cycle can be changed using the **SWITCH S2**:

0 = disabled	6 = 6 minutes
1 = 1 minute late	7 = 7 minutes
2 = 2 minute	8 = 8 minutes
3 = 3 minute	9 = 9 minutes
4 = 4 minute	10 = 10 minutes late
5 = 5 minutes late (default value)	

**X-PERT SMART
ELECTRONIC BOARD**

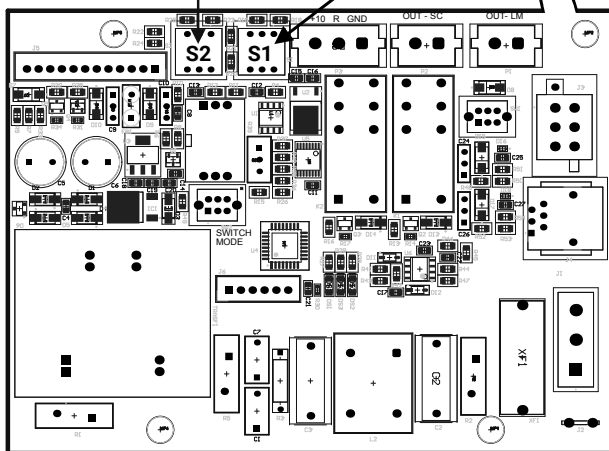

OPERATION

The filter self-cleaning is activated when the **central vacuum unit is not in operation**, it starts 30 minutes after the last use, and remains in operation for a duration of 5 minutes.

ACCESSING THE ELECTRONIC BOARD

To access the electronic board, use a screwdriver to unscrew the screw (2) located under the cap (1) and remove the dashboard.

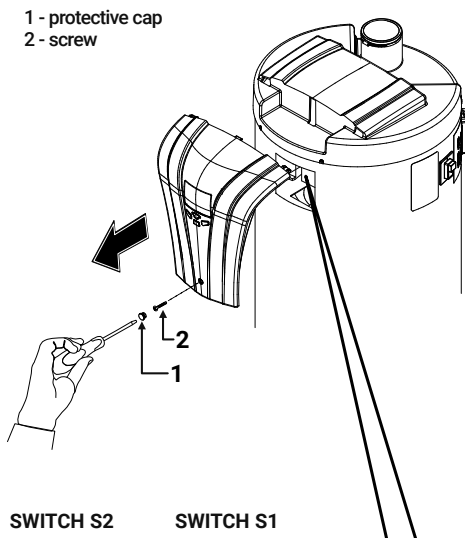

TEST OF THE CENTRAL POWER UNIT - RT1AS

The general centralised vacuum system test must be done after the final assembly of all vacuum sockets and compensation valve.

1 - Activate the central power unit with all the sockets closed and verify that the pressure on the display does not exceed 250 mBar.

If the value is greater, regulate the compensation valve so as not to exceed 250 mBar.

If the pressure on the display is too low (below 220 mBar), check the system for leaks. If there are no leaks, regulate the valve until the pressure is 250 mBar.

2 - Insert the hose in the nearest vacuum socket to the central power unit. Check the suction value on the display of the unit: the value must be between 90 and 160 mBar. If the value is within the range continue with step 3.

If the value is lower than the range check for leaks in the system.

If the value is greater than the range check for any blocks in the system.

If the problem is not solved, contact the Aertecnica Service Centre.

3 - Insert the hose in the furthest vacuum socket from the central power unit. Check the suction value on the display of the unit: the value must be between 90 and 160 mBar: if the value is within the range, the test of the RT1AS central power unit has ended positively.

If the value is lower than the range check for leaks in the system.

If the value is greater than the range check for any blocks in the system.

If the problem is not solved, contact the Aertecnica Service Centre.

NOTE: To verify that the electrical connection of the vacuum sockets is operating properly, activate the vacuum system from each outlet.

TEST OF THE CENTRAL POWER UNITS - RT2MAS - RT2AS - RT3AS

The general test for the centralised vacuum system must be done after the final assembly of all the vacuum sockets.

1 - Activate the central power unit with all sockets closed and wait a few seconds: check that the pressure on the display is equal to 160 mBar (for RT2AS and RT3AS) and 140 mBar (for RT2MAS)

If the value is lower check for leaks in the system.

If the value is higher contact the Aertecnica Service Centre.

2 - Insert the hose in the nearest vacuum socket and subsequently in the furthest from the central. Verify on the display of the unit that in both cases the value of the intake is not lower than 140 mBar. If the value is higher, continue with step 3.

If the value is lower than 140 mBar check for any leaks in the system.

3 - insert two hoses simultaneously in two vacuum sockets placed in different areas of the building. Verify on the display of the unit that the value of the intake is not lower than 100 mBar. If the value is higher, the test is successfully completed.

If the value is lower than 100 mBar check for any leaks in the system.

NOTE: To verify that the electrical connection of the vacuum sockets is operating properly, activate the vacuum system from each outlet.

ORDINARY MAINTENANCE

Careful maintenance prolongs the life-time of the central power unit and guarantees better performance.

 Before starting with any maintenance operation, disconnect the central power unit from the power supply.

 Do not insert your upper limbs inside the unhooking/hooks mechanism of the dust container.

 The central power unit must not be operated without the filter cartridge inserted. Failure to observe this rule could cause damage to the motor that is not covered by the warranty.

DUST CONTAINER OPENING

Turn the special handle (L) upwards and remove the dust container using the carrying handle (M).

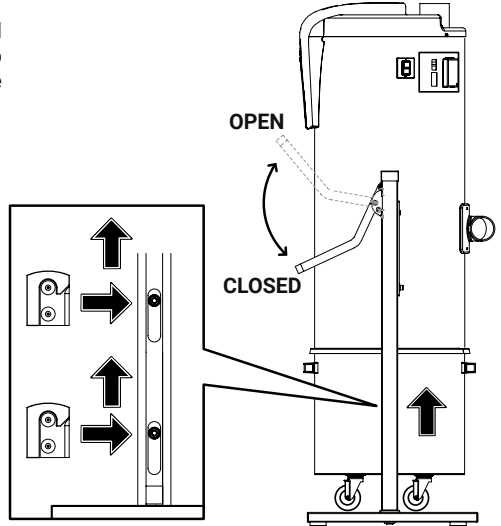
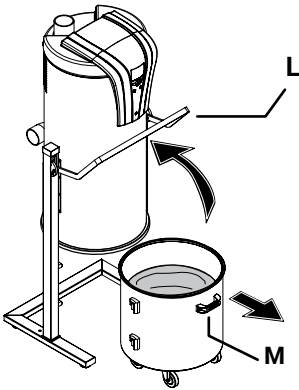

Put the container inside the frame so that the two hooks (S) of the container are flush on the two pins (P) on the left and right side of the frame.

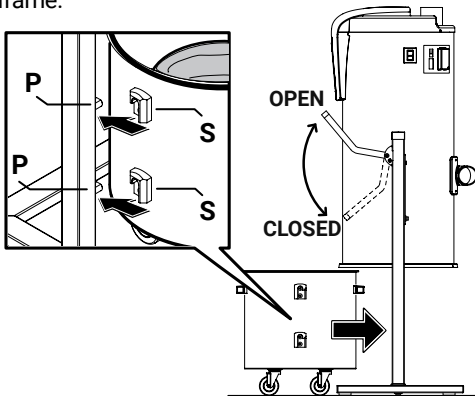

Turn the handle (L) downwards at the end of use. The coupling mechanism raises and closes the dust container.

EMPTYING THE CONTAINER

We recommend that you replace the bag before it reaches its maximum capacity.

1 - open the power unit by turning the handle (L) upwards and remove the dust container by sliding it on the 4 wheels.

2 - remove the conveyor cone (N)

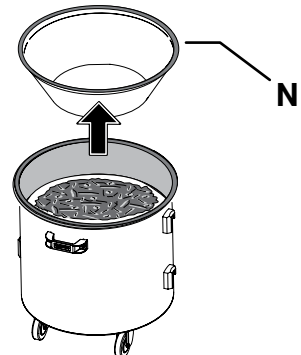

3 - Remove the bag tensioner (Q), remove the full bag (S), close it and throw it in the waste according to current environmental regulations.

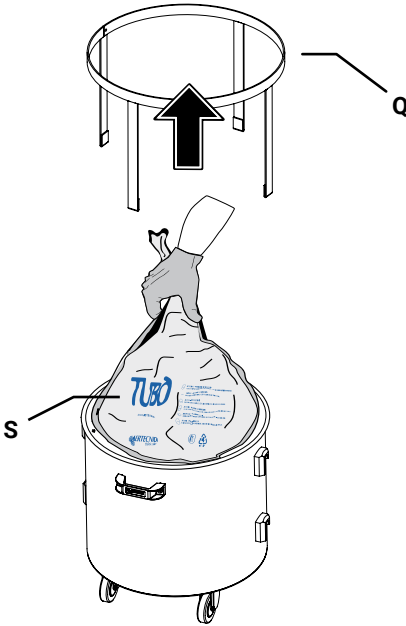

5 - reinsert the conveyor cone making sure that the rubber seal (O) is in the correct position.

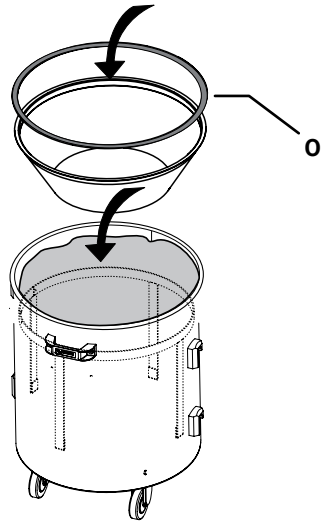

4 - insert a new dust bag into the container and insert the bag tensioner inside the bag.

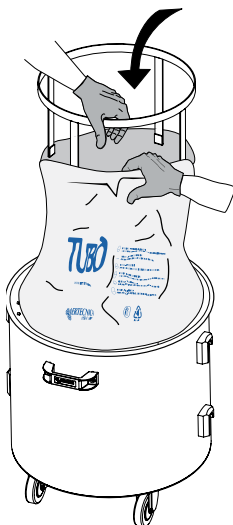

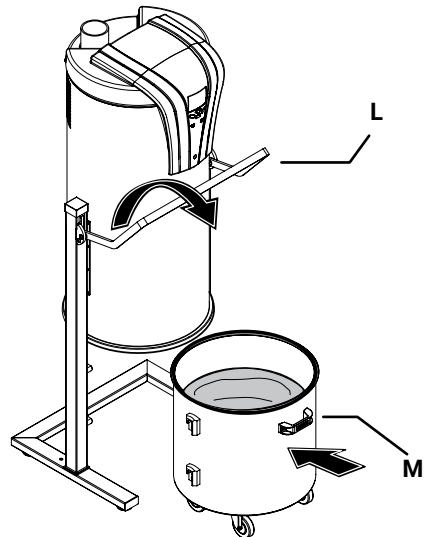

6 - reinsert the dust container using the carrying handle (M) and close the unit by turning the handle (L) to the bottom.



FILTER CARTRIDGE REPLACEMENT

 Before starting with any maintenance operation, disconnect the central power unit from the power supply.

We recommend that you replace the filter cartridge every 2-3 years. This period may change depending on the degree of system use.

ATTENTION
 When replacing the filter cartridge, it is easy to come into contact with the dust collected by the unit. Before removing the filter cartridge, we recommend that you put on personal protective garments.



The unit display indicates the percentage of saturation of the filter cartridge. Periodically check on the unit's control panel, the degree of saturation of the filter cartridge.

 The central power unit must not be put into operation without a filter cartridge placed inside it. Failure to observe this rule could cause damage to the motor that is not covered by the warranty.

 Do not insert your upper limbs inside the unhooking/hooks mechanism of the dust container.

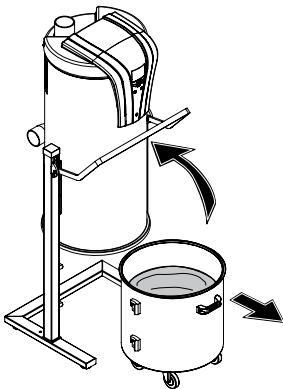
1 - Open the central power unit and remove the dust container.



2 - Unscrew the knob (b) that fastens the cartridge and remove it from its housing.

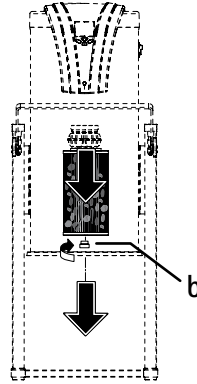

3 - Insert a new cartridge and tighten the knob completely.

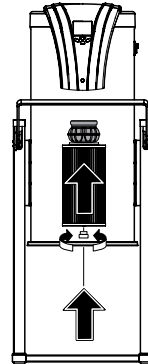

4 - Put the dust container back and close the unit.

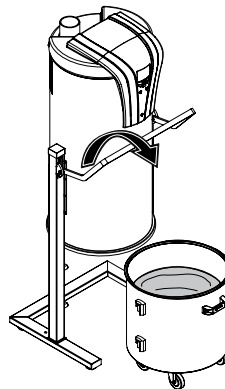

FILTER CARTRIDGE REGENERATION

ATTENTION

To effectively regenerate the saturated cartridge and keep the centralised vacuum system operating, we recommend that you insert a new filter cartridge immediately, restart the system and vacuum the largest dust particles from the saturated cartridge using the system itself.

Periodic filter cartridge regeneration improves overall centralised vacuum system productivity.

The unit display indicates the percentage of saturation of the filter cartridge. With normal use of the system it is a good idea to check the cartridge every 4 months.

ATTENTION



When regenerating the filter cartridge, it is easy to come into contact with the dust collected by the unit. Before removing the filter cartridge, we recommend that you put on personal protective garments.



1 - Vacuum the dust collected on the saturated cartridge walls using the system itself.



2 - After an initial brief cleaning, wash the filtercartridge with a jet of water that is not too strong and remove the dust that has penetrated between the walls.



3 - Allow the cartridge to dry completely and check the gasket condition (G)

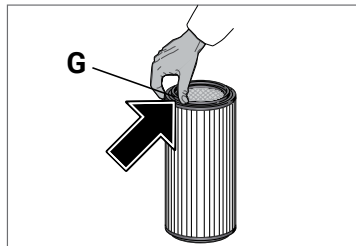

4 - Make sure that there are no tears or cuts on the cartridge walls. If there are, the damaged cartridge must be replaced with a new one.

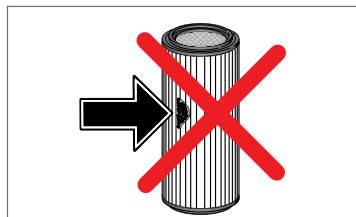

ATTENTION

CARTRIDGE GASKET CHECK

Check the gasket condition (G) of the filter cartridge. Replace if damaged.

UNIT DISPOSAL

At the end of its life cycle, the machine must be disposed of in compliance with current applicable regulations.

The following table specifies the material with which the central power unit is built.



IMPORTANT

The materials listed below must be divided and stored to be recycled or disposed of in compliance with the environmental regulations valid in the country of use.

TYPE OF MATERIAL	PRESENCE IN THE CENTRAL UNIT	SPECIFICATION	FOR DISPOSAL
Plastic and rubber	cone seals and cables	PVC 73 - DM - EPM	The regulations that govern the disposal and demolition of the central power unit, its components and the possible polluting material and substances change depending on the country of final use.
	cable gland	polyamide fibre	
	openings	polypropylene	
	rubber sleeves	SBR/NR rubber	
	filter cartridge	polyester/metal	
	filter knob	polyamide fibre	
	stickers	PVC	
	container handle	nylon	
	feet of frame stand	megol synthetic rubber	
	dust bag	polyethylene	
	caps for frame columns	PVC	
	dome	polypropylene	
self-cleaning	nylon and rubber metal		
Galvanised components	screws and rivets	steel/stainless steel/brass	We recommend that you contact the authorised organisations and agencies and respect the current applicable legal regulations
Windings	wiring	copper	
Electronic components	electronic card	electric parts	
	motor	electric parts	
	control panel	electric parts	
Sheet metal	main body, conveyor cone, dust bag tensioner, frame, opening lever, compartment separation plates, brackets	painted steel, stainless steel, galvanised steel	
Packaging	box	cardboard	
	pallet	wood	
	bags	polyethylene	
	fixing screws	galvanized steel	

TROUBLESHOOTING

The table shows generic cases of malfunctions or failures that may occur during the normal life-cycle of the vacuum cleaner unit. Follow the instructions shown.

PROBLEM	CAUSE	ACTION	
There is no air intake from all the sockets	Power supply cable disconnected	Connect the power supply cable	
	12V socket cable line not connected or incorrectly connected	Connect the 12V socket cable line or check the wiring	
	The maximum amount of time of continuous central power use has been exceeded	The microswitch of one of the vacuum sockets is damaged. Call a specialised technician.	The system remained on inadvertently for 30 consecutive minutes. Press RESET or turn the system off and on to reset operation
			Check the electric connection of the 12V socket cable line. Call a specialised technician.
			Check if the air exhaust line is free or if the two air exhaust openings are blocked. Wait for the motor to cool down. Press RESET to reset operation
	The motor overheated. The motor temperature exceeded 90 °C.		Make sure the filter cartridge is not saturated. In this case, perform maintenance. Wait for the motor to cool down. Press RESET to reset operation
		The vacuum exceeded 240 mbar for more than 15 seconds	The hose inlet is obstructed. Free the hose, turn the system on and off and press RESET
	The dust container is not correctly hooked	Rehook the container correctly.	
There is no air intake from one of the sockets	The microswitch or the electric contacts of one of the vacuum sockets is damaged.	Call a specialised technician.	
	There is clogging in the system	Call a specialised technician.	

PROBLEM	CAUSE	ACTION
Low amount of air intake	There is clogging in the system	Call a specialised technician.
	The filter cartridge is saturated	Perform cartridge maintenance. Press RESET to reset operation.
	A greater number of hoses have been connected to the system compared to the characteristics of the power unit.	The control unit can be used at the most, by the number of operators indicated in the table
	The dust container gasket is damaged or out of position	Check the gasket position of the dust container.
	The air exhaust line is clogged	Verify that the air exhaust line is free
	The hose is partially obstructed.	Free the obstruction from the hose.
The central power unit always remains activated even with the sockets closed	The microswitch or the electric contacts of one of the vacuum sockets is damaged.	Call a specialised technician.
The display stays off	The main switch of the building is turned off	Turn the main switch back on
	The control unit switch is turned off	Press the green button on the control unit
	The electronic card is defective.	Call a specialised technician.
Call a specialised technician for other causes that are not covered in this manual		



EN

The descriptions and illustrations may change. Aertecnica SpA reserves the right to modify the product and the related technical documentation without incurring any obligation to third parties.

AERTECNICA S.p.A.

Via Cerchia di Sant'Egidio, 760 - 47521 Cesena (FC) - ITALY

Tel. +39 0547 637311

info@aertecnica.com

www.aertecnica.com

