

CLASSIC PRE-SEPARATOR

LT40/A pre separator - Code CI541

The **CLASSIC dust pre-separator** is a modular component of the **TUBÒ** system.

Thanks to its cyclonic suction system, it **separates and collects the larger and heavier particles of dust**, which are conveyed into the large dust container.

Installed upstream of the dust separator, it **retains up to 98% of the vacuumed dust**, drastically reducing maintenance requirements. It protects the main filter and **helps maintain high performance throughout the entire system**.

Operating airflow rate up to 300 m³/h *

The **dust container** has a **40-liter capacity** and is equipped with a conveying cone that facilitates dust accumulation at the bottom.

** For central vacuum units with operating airflow rates exceeding 300 m³/h, multiple pre-separators connected in parallel are required.*



Complementary accessories



CI818 - LT40/A (CI540 / CI541) Bags for pre-separator
(10 pieces pack)

Spare

Contains protection kit
with mask and gloves

CLASSIC pre-separator		
Model		LT40/A
Commercial code		CI541
Max air flow rate	m ³ /h	300
Dust container capacity	litres	40
Pre separator diameter	cm	36
Dust inlet diameter	∅	63
Air exhaust diameter	∅	63
Weight	kg	20

LT40/A PRE-SEPARATOR WITH MODULAR CENTRAL UNIT CONNECTIONS

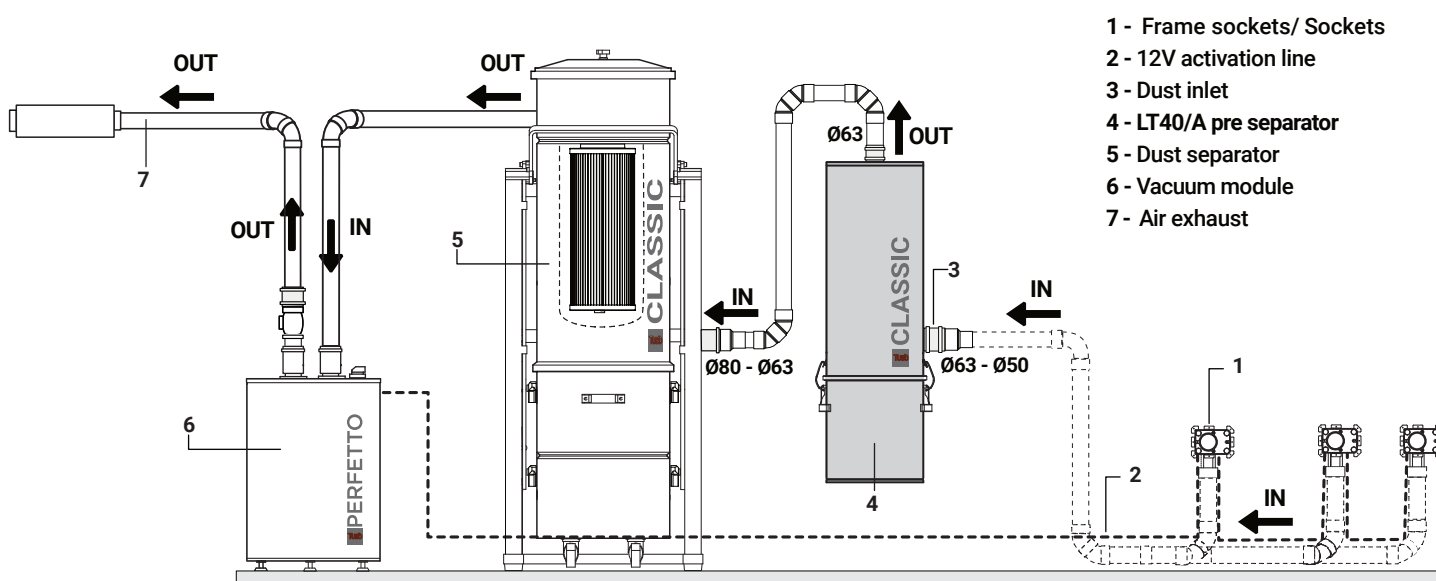

INSTALLATIONS ALLOWANCES (in cm)

